

Sliding Systems
سری کشویی نرمال

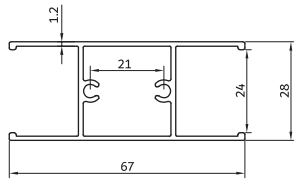



KA-1405

سپری لنگه ۵۵

690 gr/m

tripetalous profiles

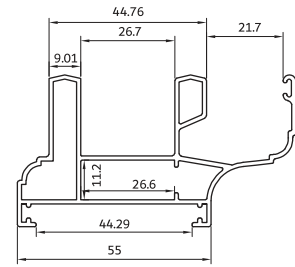

KA-1255

فریم کشویی ۵۵ توری خور

1000 gr/m

rail grid with frame

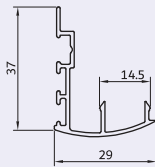

KA-105

درپوش لنگه ۵۵

290 gr/m

gap

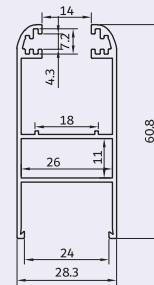

KA-1205

لنگه کشویی ۵۵

700 gr/m

vent profiles

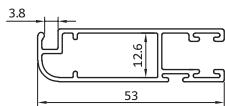

KA-539

فریم توری کشویی

510 gr/m

grid vent

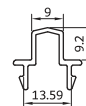

KA-205

زهوار چهار لنگه ۵۵

180 gr/m

the middle four vent

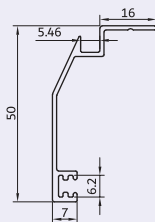

KA-550

روکوب

430 gr/m

suppressed the bilding

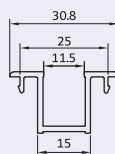

KA-513

زهوار تک جداره کشویی

280 gr/m

glass holder

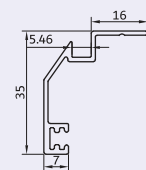

KA-535

روکوب

320 gr/m

suppressed the bilding

پنجره کشویی

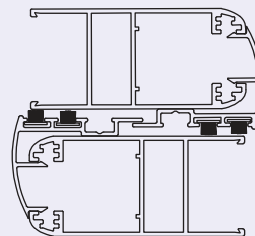
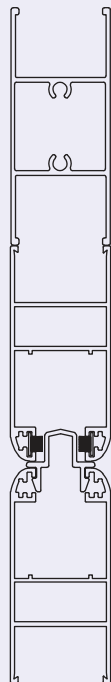
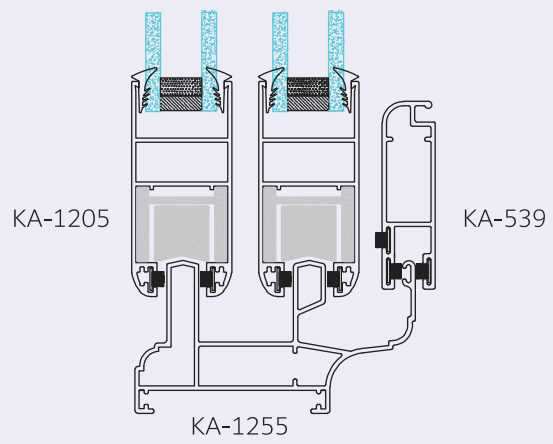
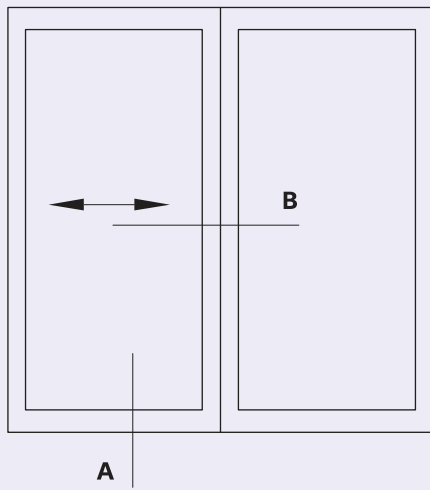

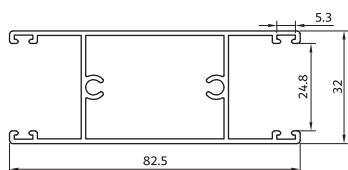

KA-1402 سپری لنگه ۶۰
940 gr/m tripetalous profiles

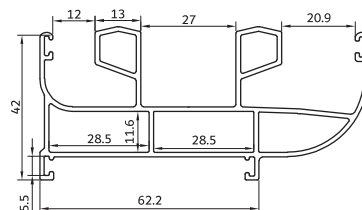

KA-1252/1 فریم کشویی ۶۰ لبه دار
1400 gr/m rail grid with frame

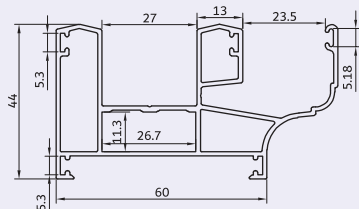

KA-1252 فریم کشویی ۶۰ لبه دار
1200 gr/m rail grid with frame

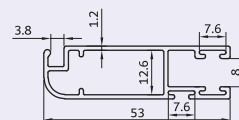

KA-539 فریم توری کشویی
510 gr/m grid vent

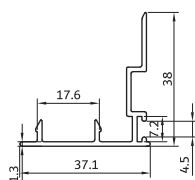

KA-516 درپوش لنگه ۶۰
340 gr/m gap

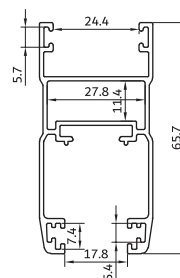

KA-1202/1 لنگه کشویی ۶۰ طرح دار
860 gr/m vent profiles

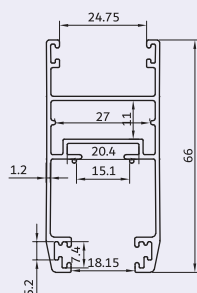

KA-1202 لنگه کشویی ۶۰
870 gr/m vent profiles

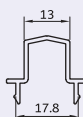

KA-512 زهوار چهار لنگه ۶۰ و ۹۰
180 gr/m the middle four vent

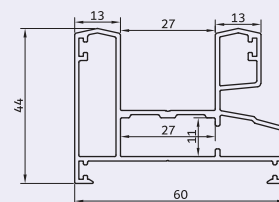

KA-1252/5 فریم کشویی ۶۰ ساده
1000 gr/m profiles frame simpel



KA-202

105 gr/m

تسمه یراق کشویی

strap profiles

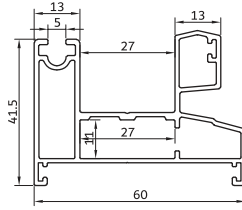

KA-1257/1

1025 gr/m

فریم کشویی ۶۰ ساده

profiles frame simpel

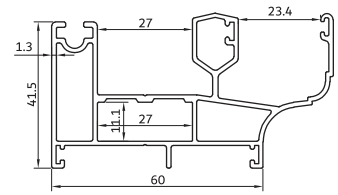

KA-1257

1218 gr/m

فریم کشویی ۶۰ توری خور

rail grid with frame

پنجره کشویی

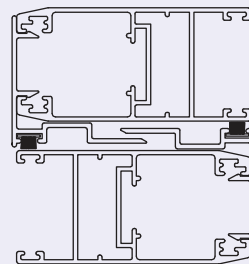
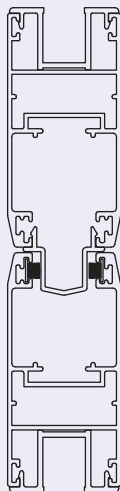
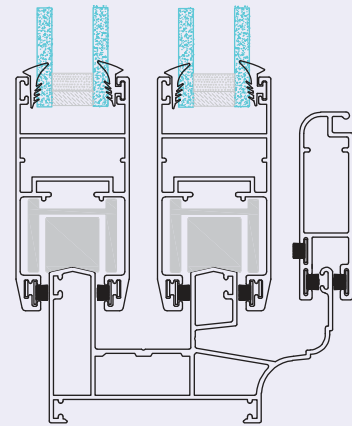
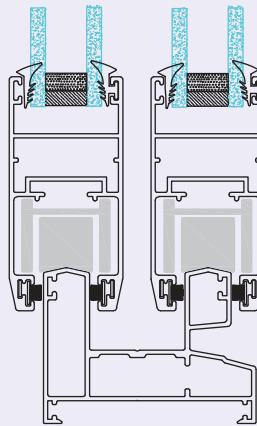
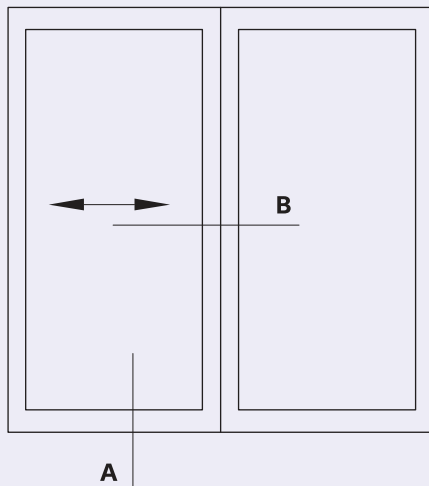

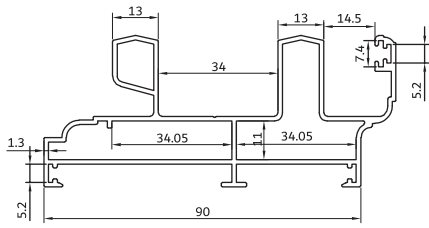

KA-1252/3 فریم کشویی ۹۰ ساده
1390 gr/m profiles frame simple

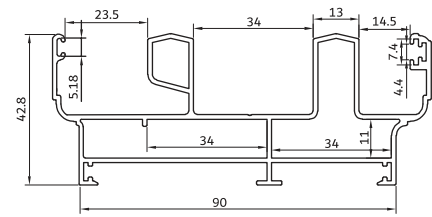

KA-1252/2 فریم کشویی ۹۰ توری خور
1860 gr/m rail grid with frame

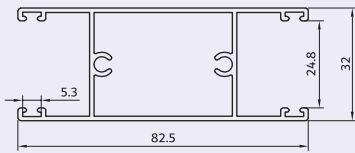

KA-1402 سپری لنگه ۶۰
940 gr/m tripetalous profiles

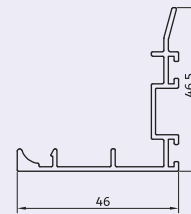

KA-516/2 درپوش لنگه ۹۰
480 gr/m gap

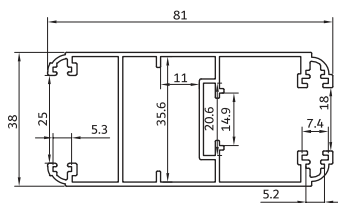

KA-1202/2 لنگه کشویی ۹۰
1100 gr/m vent profiles

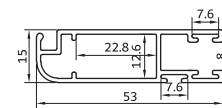

KA-539 فریم توری کشویی
510 gr/m grid vent

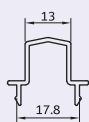

KA-512 زهوار چهار لنگه ۶۰ و ۹۰
180 gr/m the middle four ven



KA-202 تسمه یراق کشویی
105 gr/m strap profiles

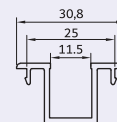

KA-513 زهوار تکجداره کشویی
280 gr/m glass holder

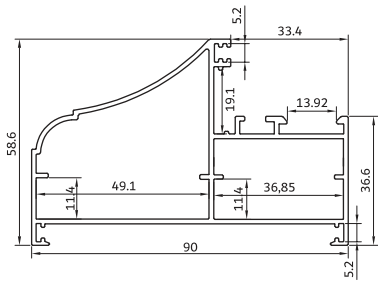

KA-153

1280 gr/m

چهارچوب لولایی ۹۰
profiles engraving

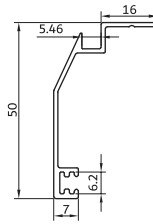

KA-550

430 gr/m

روکوب
suppressed the bilding

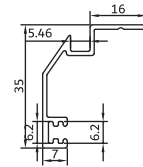

KA-535

320 gr/m

روکوب
suppressed the bilding

پنجره کشویی

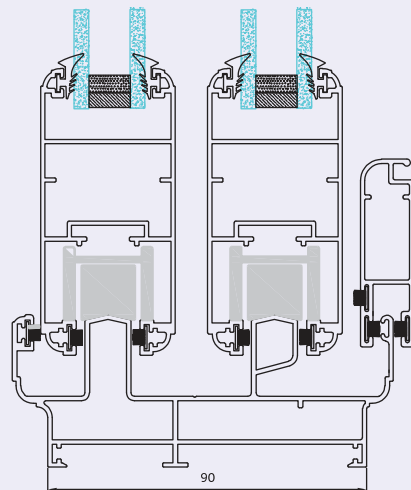
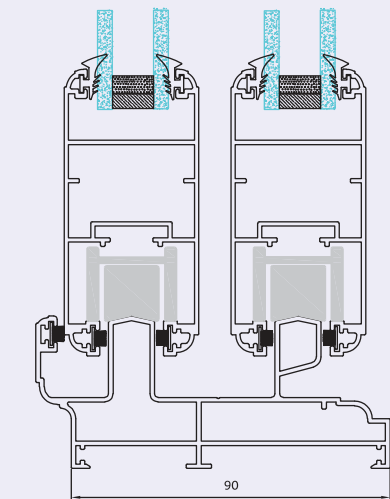
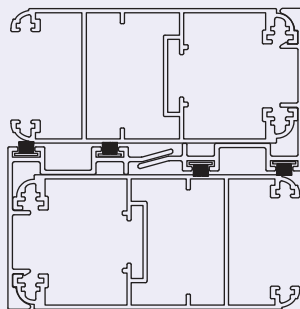
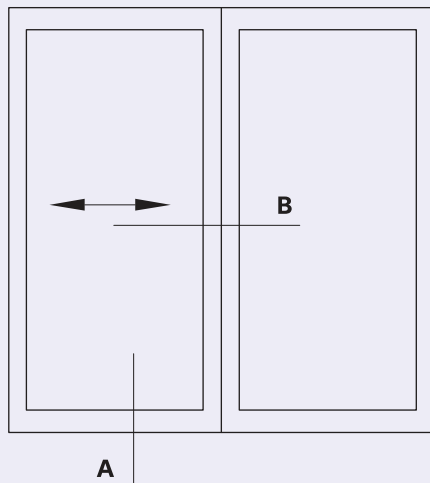

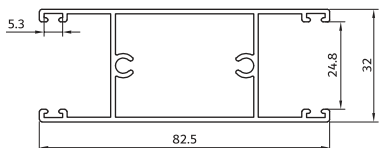

KA-1402

سپری لنگه ۶۰

940 gr/m

tripetalous profiles

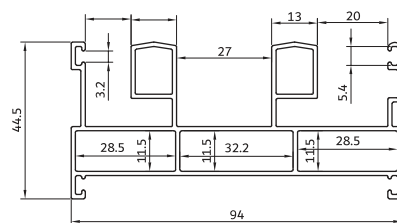

KA-1252/4

فریم کشویی ۹۴ توری خور

1430 gr/m

rail grid with frame

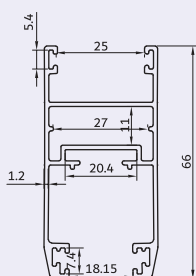

KA-1202

لنگه کشویی ۶۰

870 gr/m

vent profiles

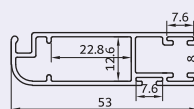

KA-539

فریم توری کشویی

510 gr/m

Grid vent

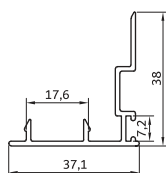

KA-516

لنگه کشویی ۶۰

340 gr/m

gap

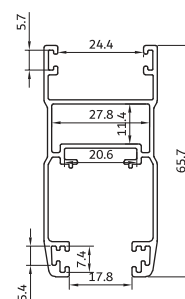

KA-1202/1

لنگه کشویی ۶۰ طرح دار

860 gr/m

vent profiles

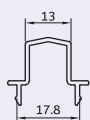

KA-512

زهوار چهار لنگه ۶۰ و ۹۰

180 gr/m

the middle four vent



KA-202

تسمه پراق کشویی

105 gr/m

strap profiles

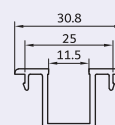

KA-513

زهوار تکجداره کشویی

280 gr/m

glass holder

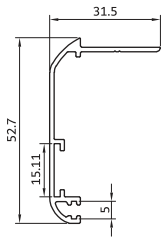

KA-452

روکوب ۵۲

398 gr/m bilding suppressed the bilding

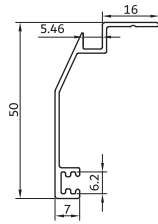

KA-550

روکوب ۵

430 gr/m bilding suppressed the bilding

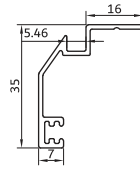

KA-535

روکوب ۳.۵

320 gr/m bilding suppressed the bilding

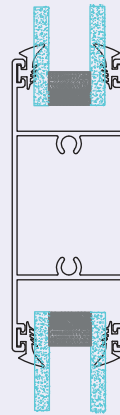
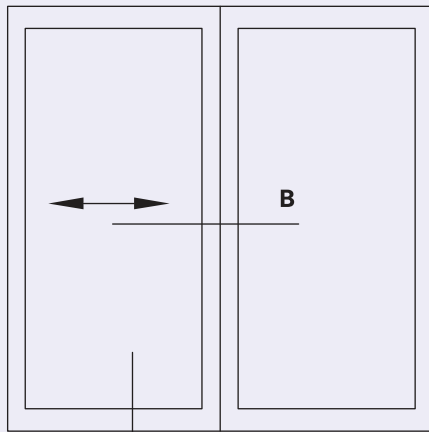

پنجره کشویی لبه دار

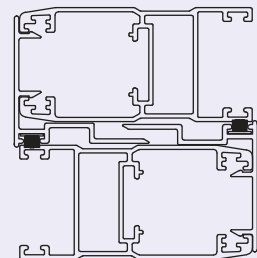
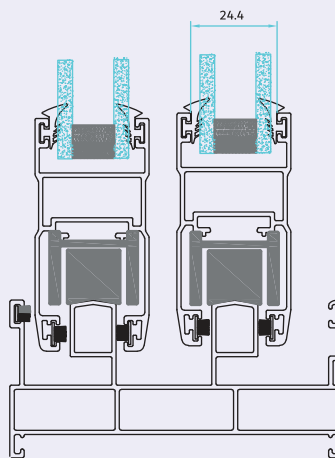
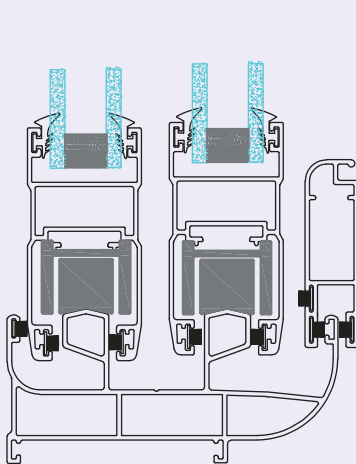

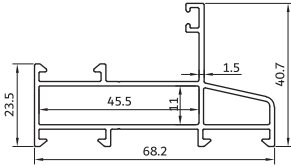
**KA-5268**

چهارچوب کتیبه

840 gr/m

profiles engraving

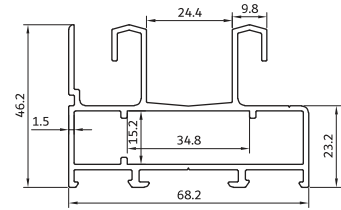
**KA-1255/c2**

چهارچوب کشویی

1270 gr/m

profiles frame simpel

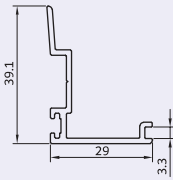
**KA-530/c2**

درپوش دماغه لنگه کشویی

340 gr/m

Gap

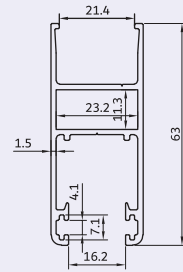
**KA-1205/c2**

لنگه کشویی

800 gr/m

vent profiles

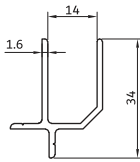
**KA-508/c2**

ریل توری کشویی بالا

340 gr/m

grid rails up

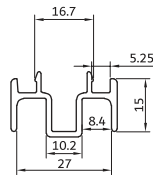
**KA-512/c2**

وسطی چهار لنگه کشویی

300 gr/m

the middle four vent

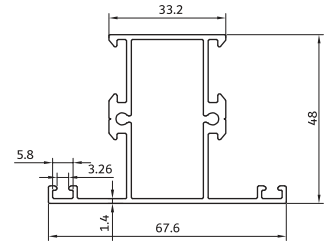
**KA-5400**

سپری لولایی

1000 gr/m

tripetalous profiles

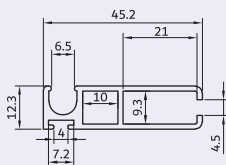
**KA-5539**

فریم توری

500 gr/m

Grid vent

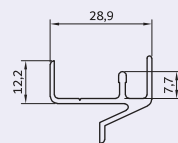
**KA-507/c2**

ریل توری کشویی پایین

300 gr/m

grid rails down

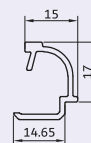
**KA-5150**

زهوار دو جداره گرد

220 gr/m

glass holder

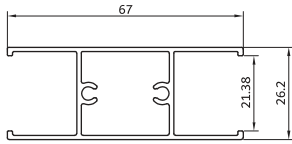

KA-1405/c2

سپری لنگه ۵۵

690 gr/m

tripetalous profiles

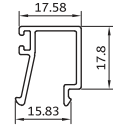

KA-1150

زهوار دو جداره تخت

245 gr/m

glass holder

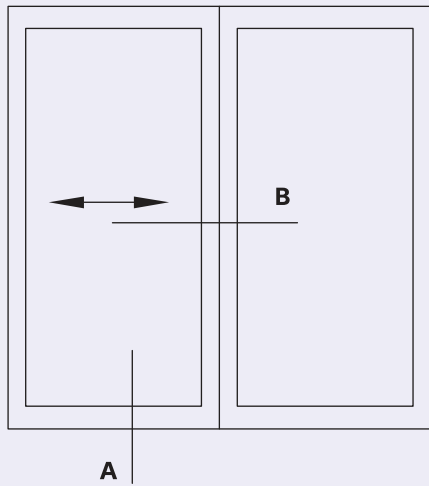

پنجره کشویی سری کی

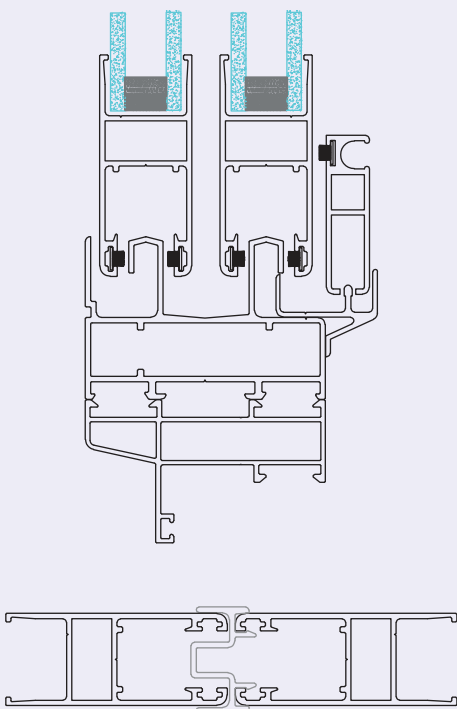
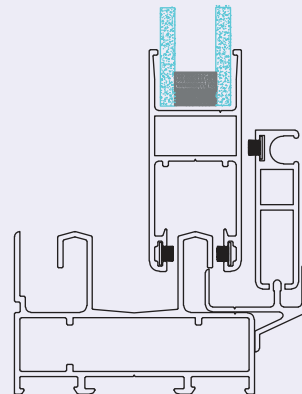
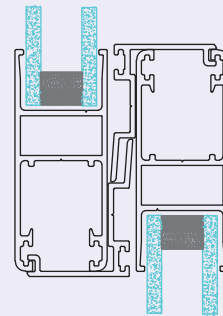
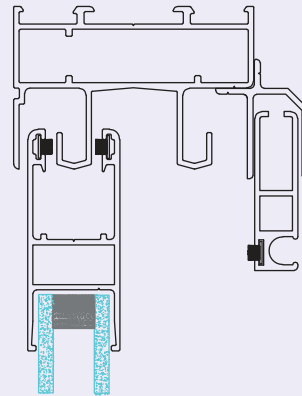



Habibi Industrial Group

Manufacturer of All Kinds of

DC Billet

Aluminum Sections

Powder Coating

Anodizing

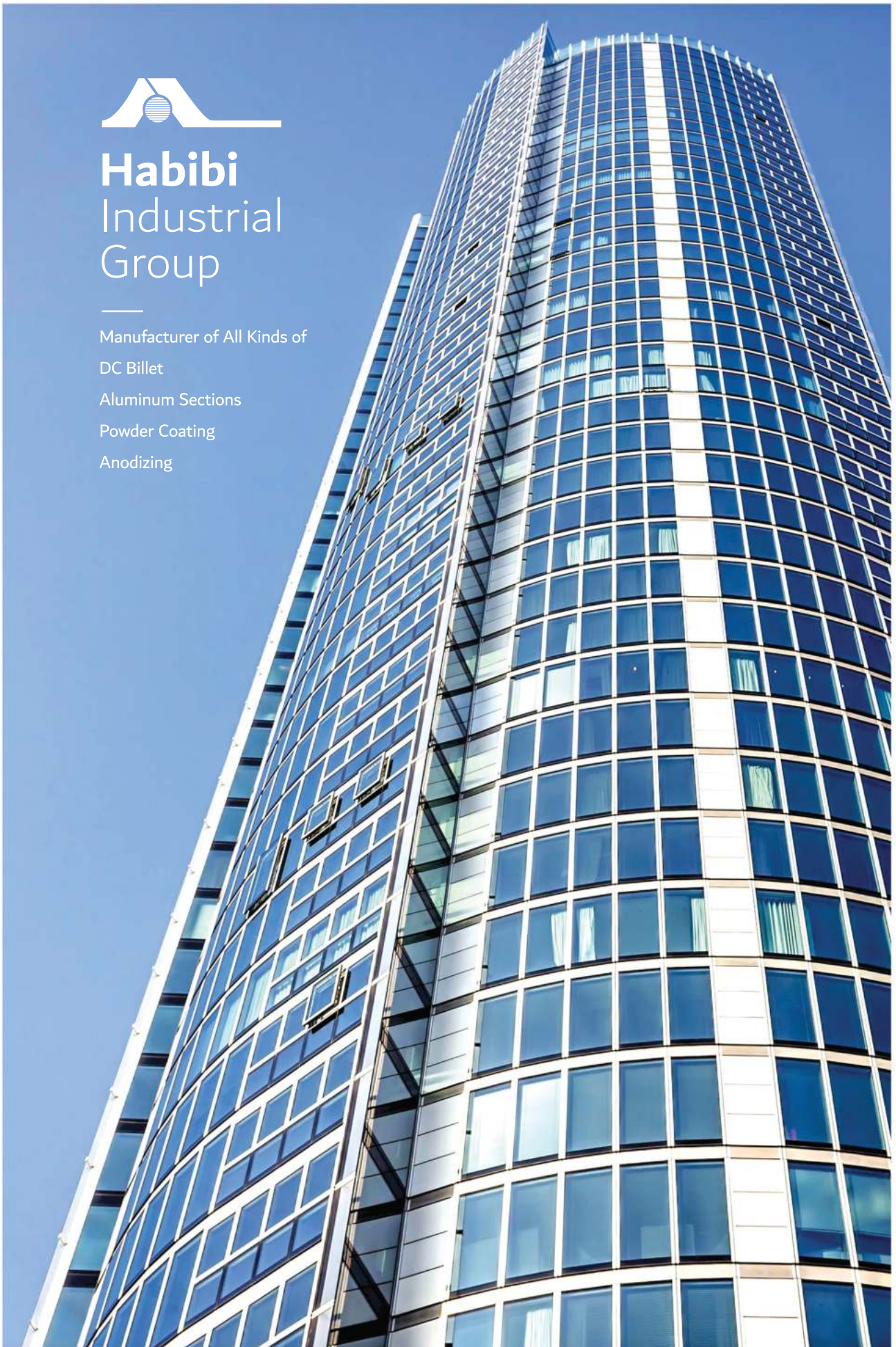

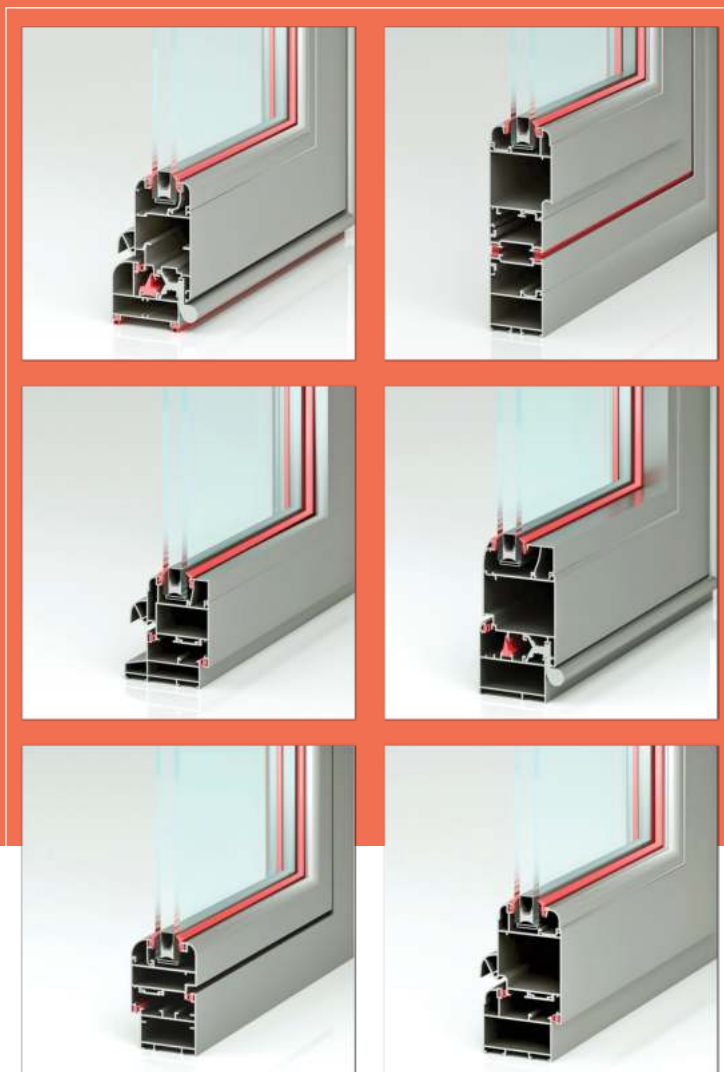

Hinged Window
سری لولایی نرمال



Hinged Window

پنجره سری ۴۷ نرمال

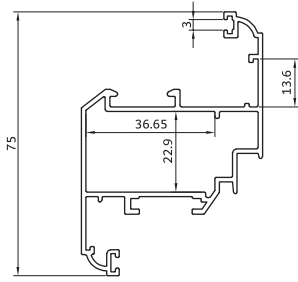
**KA-1200/1**

لنگه پنجره متوسط

980 gr/m

vent profilis

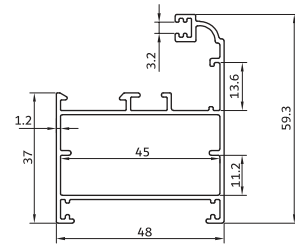
**KA-1250**

چهارچوب لولایی ۴۷

750 gr/m

frame profilis

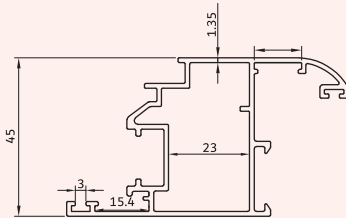
**KA-120**

لنگه پنجره اسپانیولیت خور

1020 gr/m

vent profilis

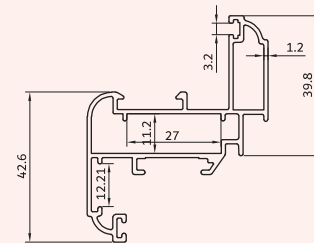
**KA-1200**

لنگه پنجره کوچک

770 gr/m

vent profilis

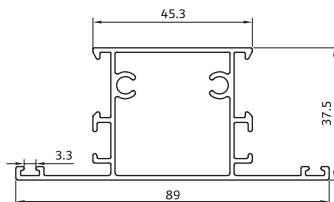
**KA-1401**

سپری پهن

940 gr/m

tripetalous profilis

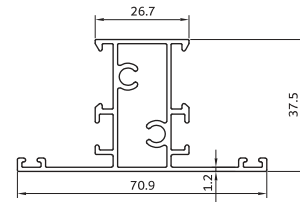
**KA-1400**

سپری باریک

850 gr/m

tripetalous profilis

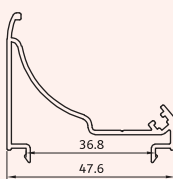
**KA-447**

آداپتور کنج ۴۷

454 gr/m

rotating frame profilis

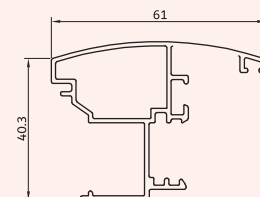
**KA-1249**

دماغه متحرک دولنگه بازشو

730 gr/m

the middle vent profilis

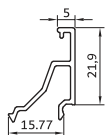

KA-1150 زهوار دو جداره
200 gr/m glass holder

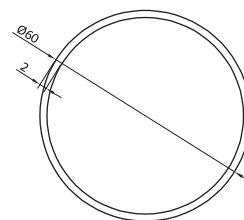

KA-60 لوله شصت
980 gr/m axial tube

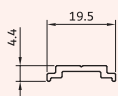

es-515 تسمه رابط
100 gr/m strap profiles

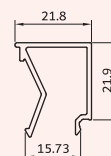

KA-1100 زهوار تک جداره
270 gr/m glass holder



Habibi
Industrial
Group |

Manufacturer of All Kinds of
DC Billet
Aluminum Sections
Powder Coating
Anodizing

پنجره لولایی سری ۴۷

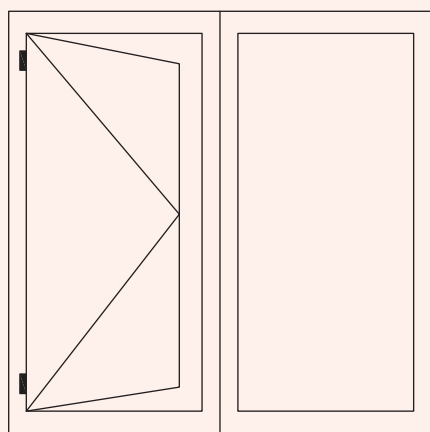

B

A

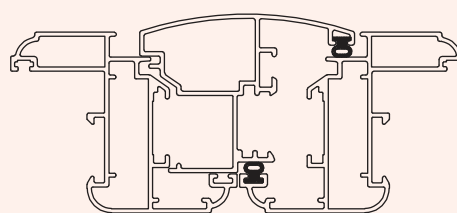
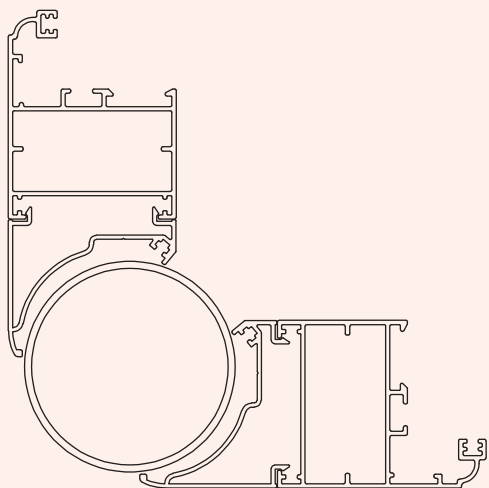
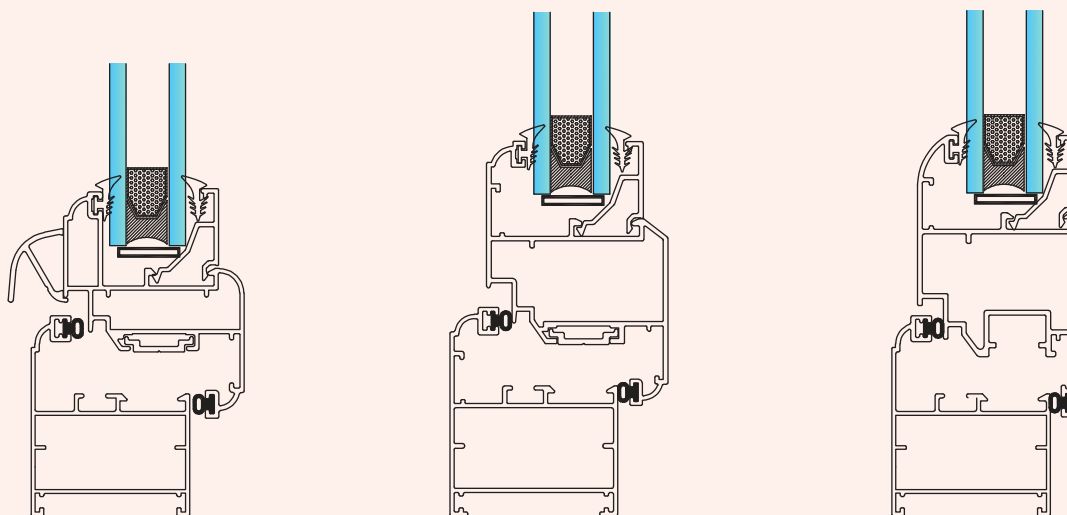

درب لولایی سری ۶۰ و ۹۰

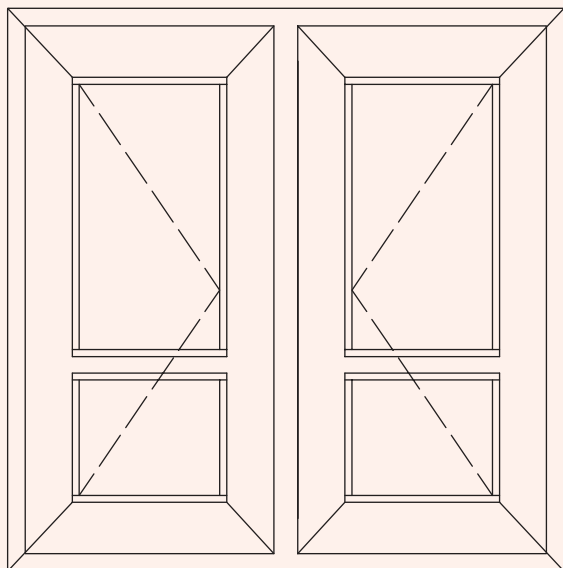

B

A

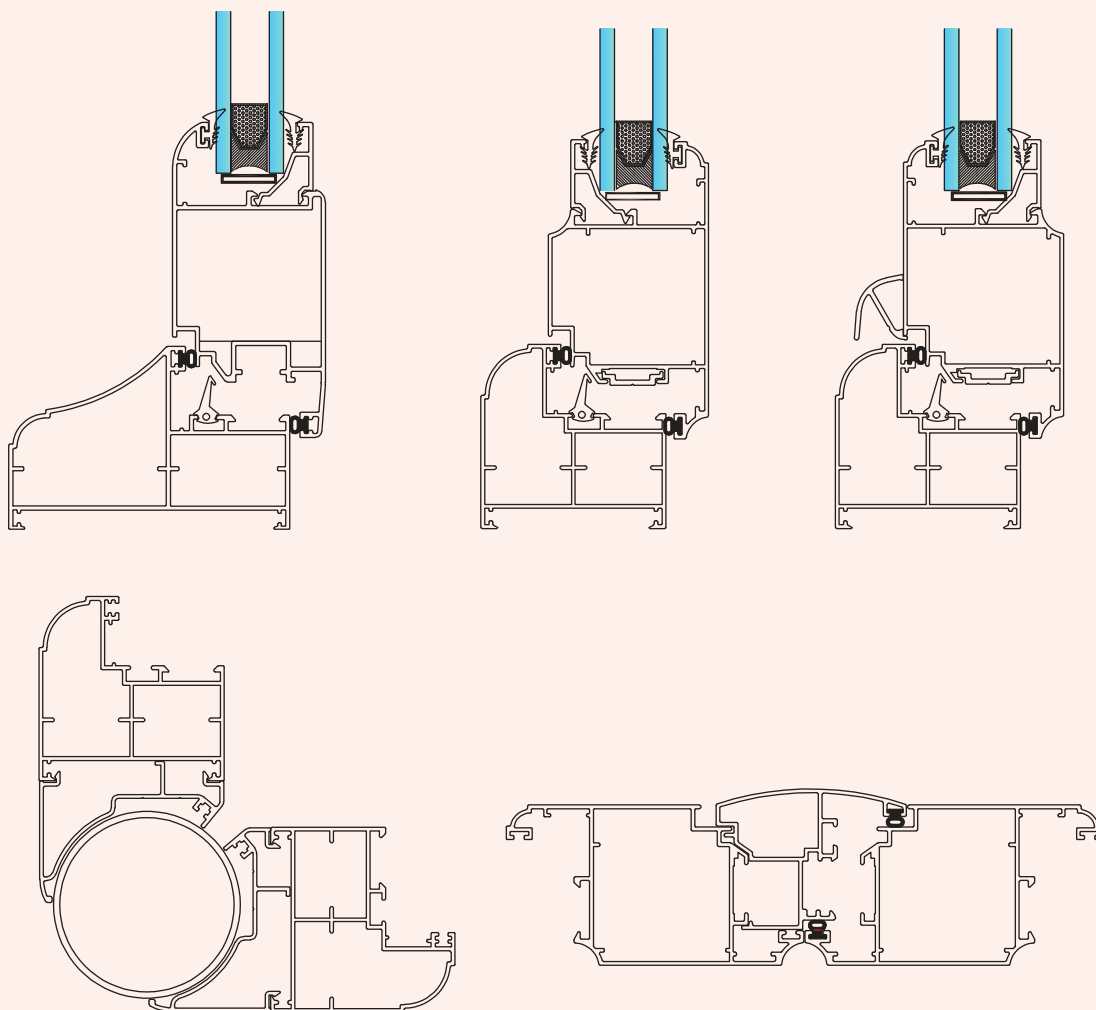

Hinged Door

درب لولایی ۵۹ و ۹۰

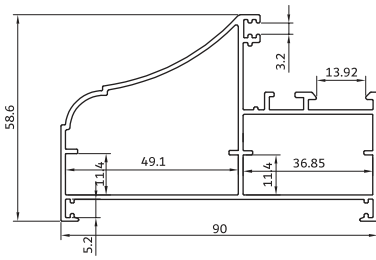

KA-153

1280 gr/m

چهارچوب لولایی ۹۰

frame profils

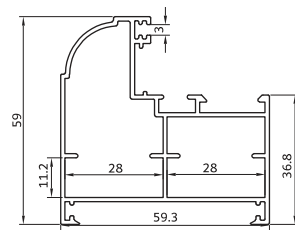

KA-1251

1150 gr/m

چهارچوب لولایی ۵۹

frame profils

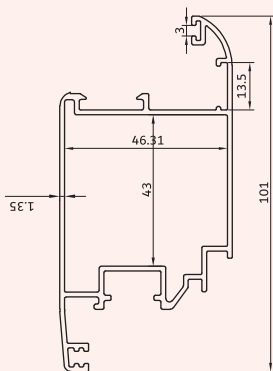

KA-121

1230 gr/m

لنگه درب اسپانیولیت خور

vent profils

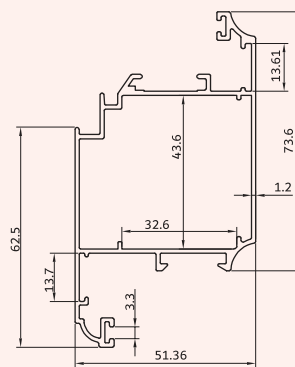

KA-1201

1100 gr/m

لنگه درب داخل بازشو

vent profils

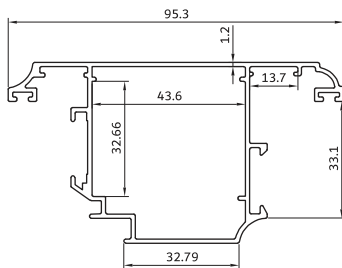

KA-1203

1080 gr/m

لنگه درب بیرون بازشو

vent profils

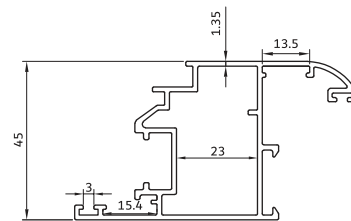

KA-120

1020 gr/m

لنگه پنجره اسپانیولیت خور

vent profils

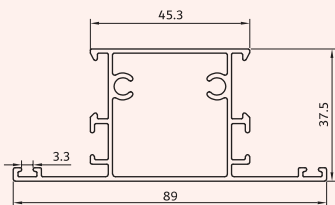

KA-1401

940 gr/m

سپری پهن

tripetalous profils

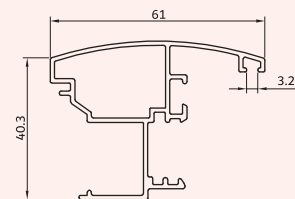

KA-1249

730 gr/m

دماغه متحرک دو لنگه بازشو

the middle vent profils

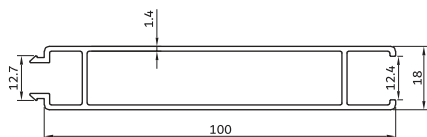
**KA-521**

930 gr/m

فاساد دو جداره

Double sheet

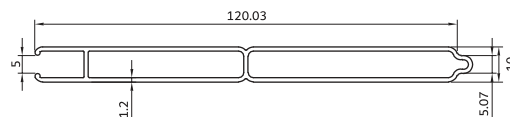
**KA-522**

870 gr/m

فاساد تک جداره

Double sheet

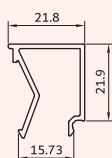
**KA-1100**

270 gr/m

زهوار تک جداره

glass holder

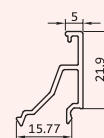
**KA-1150**

200 gr/m

زهوار دو جداره

glass holder

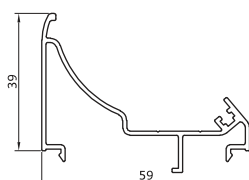
**Ka-659**

540 gr/m

آداپتور کنج ۵۹

rotating frame profiles

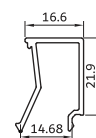
**KA-1101**

250 gr/m

زهوار دو جداره

glass holder

**es-515**

100 gr/m

تسمه رابط

strap profiles

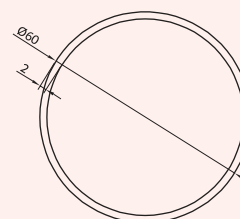
**Ka-60**

980 gr/m

لوله شصت

axial tube

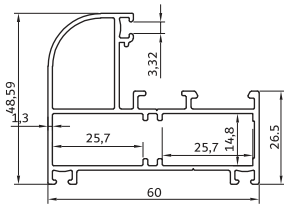

KL-1251 / 1

1000 gr/m

چهارچوب لولایی ۶۰

frame profiles

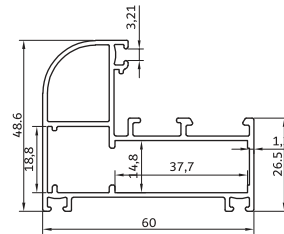

KL-1251

1000 gr/m

چهارچوب لولایی ۶۰

frame profiles

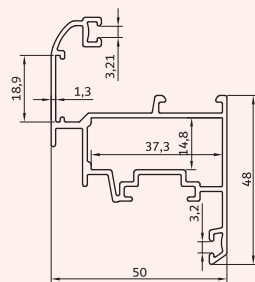

KL-1200

935 gr/m

لنگه پنجره لولایی

vent profiles

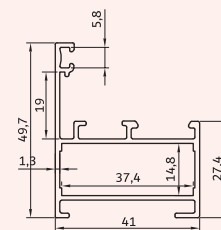

KL-1250

690 gr/m

چهارچوب لولایی ۴۱

frame profiles

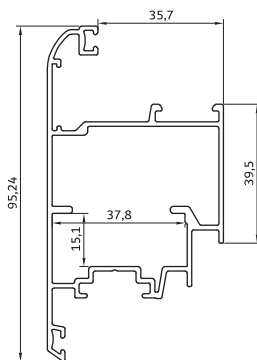

KL-1201 / B

1250 gr/m

لنگه در بیرون بازشو

vent profiles

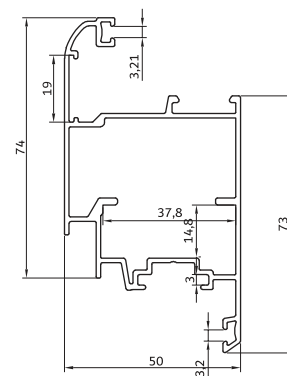

KL-1201

1250 gr/m

لنگه در لولایی

vent profiles

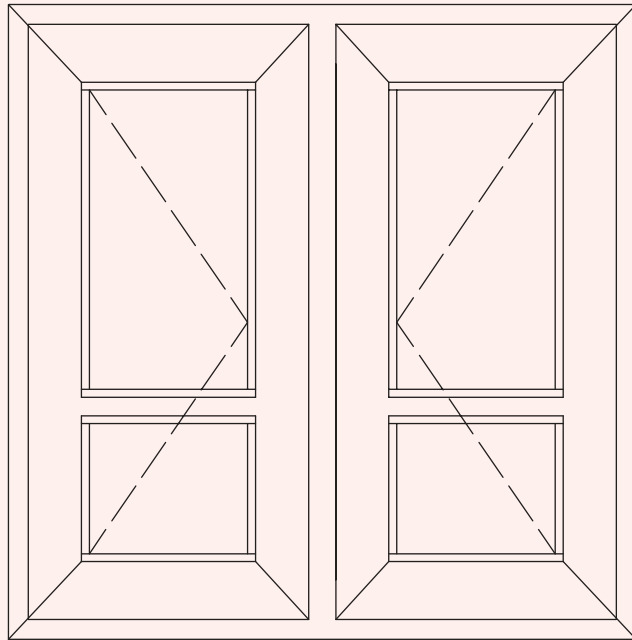

A

در ب لولایی سری لوکس

B

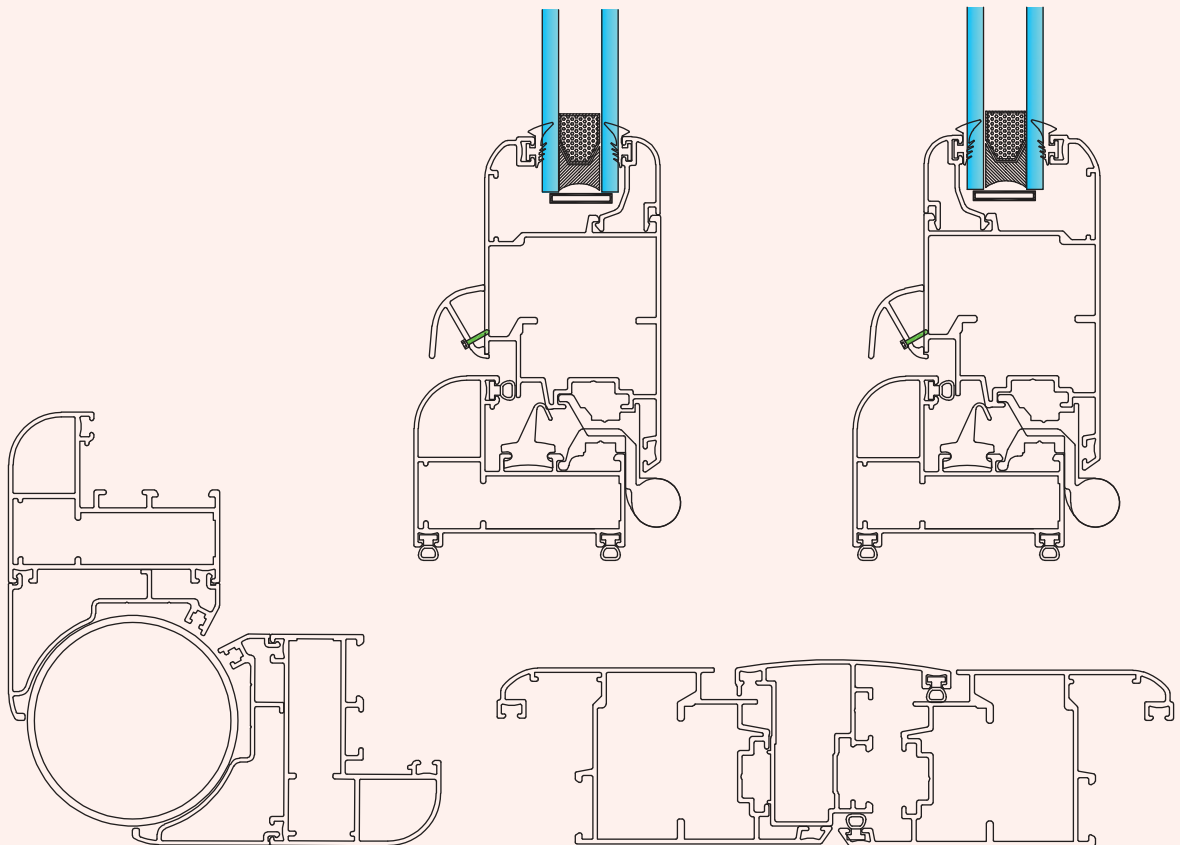
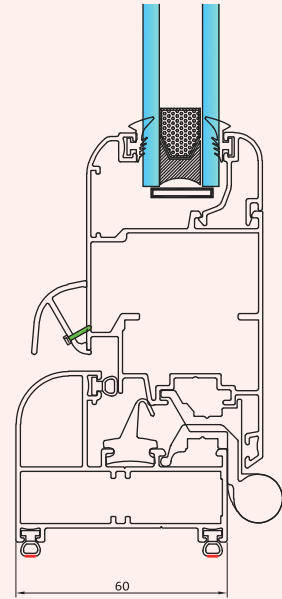

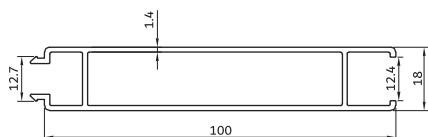
**KA-521**

فاساد دو جداره

930 gr/m

Double sheet

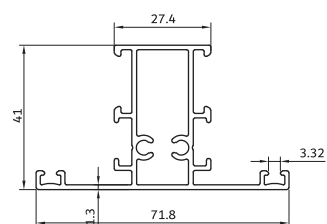
**KL-1400**

سپری لولایی

890 gr/m

tripetalous profiles

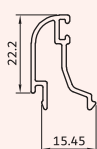
**KL-1150**

زهوار دو جداره

240 gr/m

glass holder

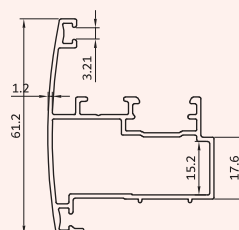
**KL-1249**

دماغه متحرک دو لنگه بازشو

770 gr/m

the middle vent profiles

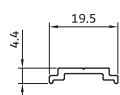
**es-515**

تسمه رابط

100 gr/m

strap profiles

**KA-510**

آبچکان لنگه

220 gr/m

water dropper profiles

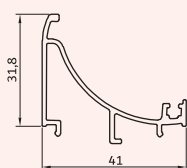
**KL-401**

آداپتور لوله ۴۰

410 gr/m

rotating frame profiles

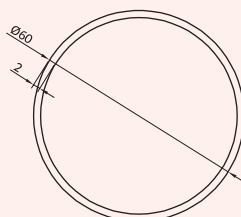
**KA-60**

لوله ۶۰

980 gr/m

axial tube

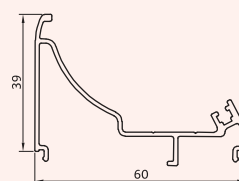
**KL-601**

آداپتور لوله ۶۰

525 gr/m

rotating frame profiles

پنجره لولایی سری لوکس

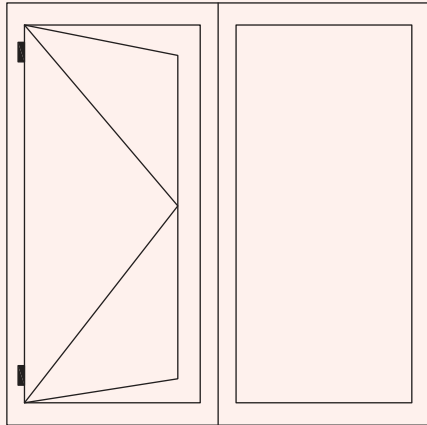

A

B

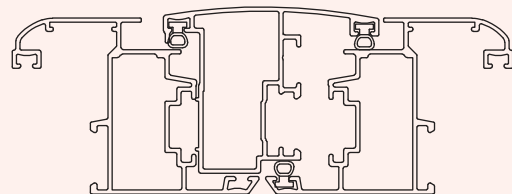
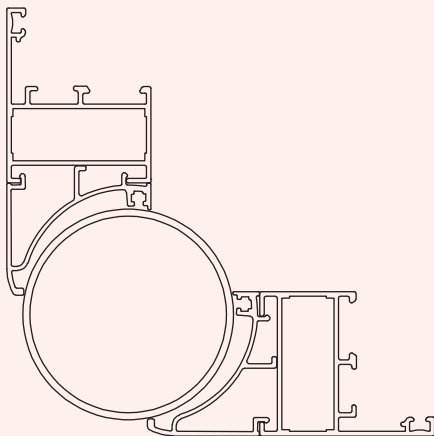
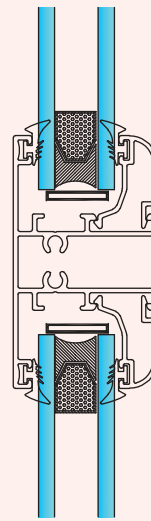
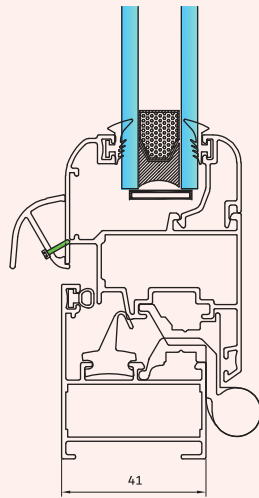

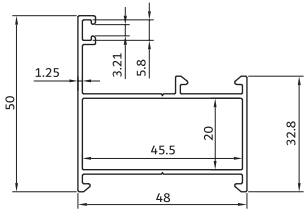

KA-5250 / 1 چهارچوب لولایی سبک
670 gr/m frame profiles

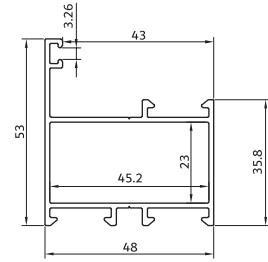

KA-5250 چهارچوب لولایی ۴۸
820 gr/m frame profiles

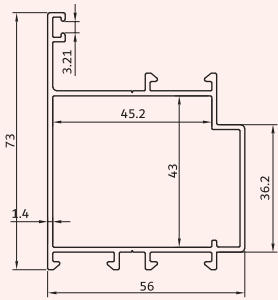

KA-5251 چهارچوب لولایی در
1030 gr/m frame profiles

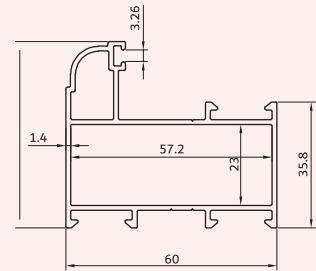

KA-5260 چهارچوب لولایی ۶۰
1040 gr/m frame profiles

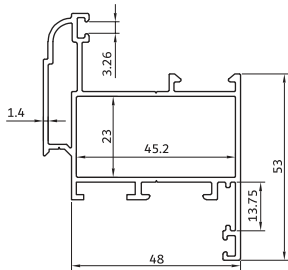

KA-5200 لنگه پنجره ۴۸
1100 gr/m vent profiles

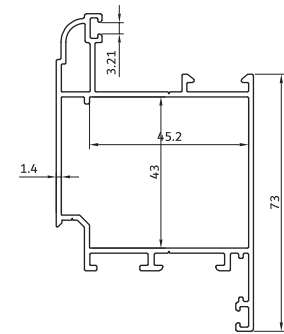

KA-5201 لنگه در لولایی
1240 gr/m vent profiles

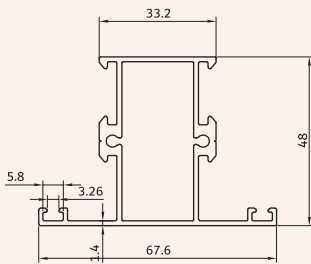

KA-5400 سپری لولایی
1000 gr/m tripetalous profiles

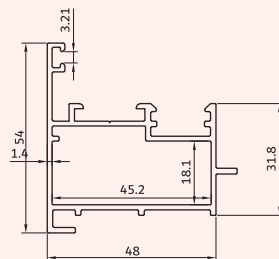

KA-5249 دماغه متحرک دو لنگه بازشو
890 gr/m the middle vent profiles

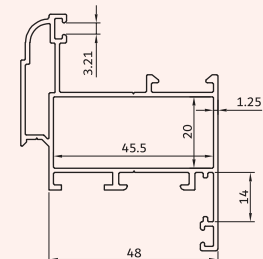

KA-5200 / 1 لنگه پنجره سبک ۴۸
1000 gr/m frame profiles

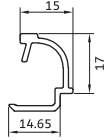
**KA-5150**

220 gr/m

زهوار دوجداره گرد

glass holder

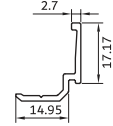
**KA-5051**

165 gr/m

زهوار تک جداره

glass holder

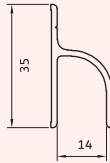
**KA-545**

290 gr/m

ریل توری لولایی بالا

grid rails up

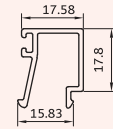
**KA-1150.tr**

245 gr/m

زهوار دوجداره تخت

glass holder

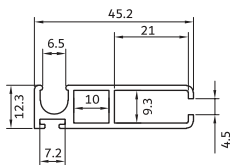
**KA-5539**

500 gr/m

فریم توری

grid vent

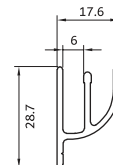
**KA-546**

330 gr/m

ریل توری لولایی پایین

grid rails down

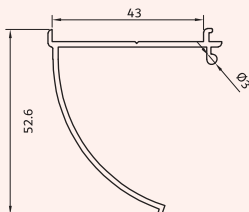
**KA-S520 / A**

500 gr/m

آداپتور کنج متحرک

rotating frame

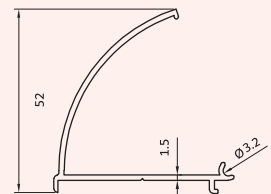
**KA-S520 / B**

500 gr/m

آداپتور کنج متحرک

rotating frame

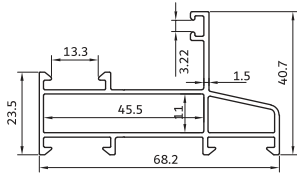

KA-5268

840 gr/m

چهارچوب کتیبه
frame profiles

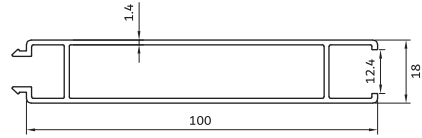

KA-521

930 gr/m

فاساد دوجداره
double sheet

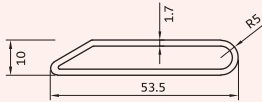

KA-S510

490 gr/m

لوور ثابت
louvre

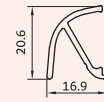

KA-510

220 gr/m

آبچکان لنگه
water dropper profiles

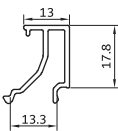

KA-5101

220 gr/m

زهوار دوجداره
glass holder

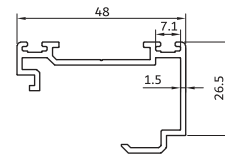

KA-5260

540 gr/m

آداپتور در بادبزی
the middle vent

KA-S1351

1900 gr/m

قیید پهن لولایی
tripetalous profiles

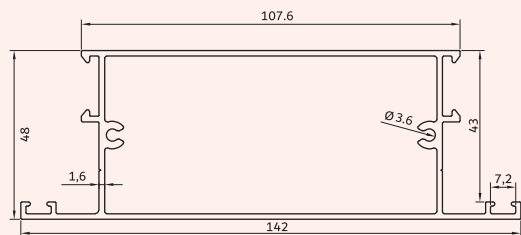

درب لولایی سری ۵۰

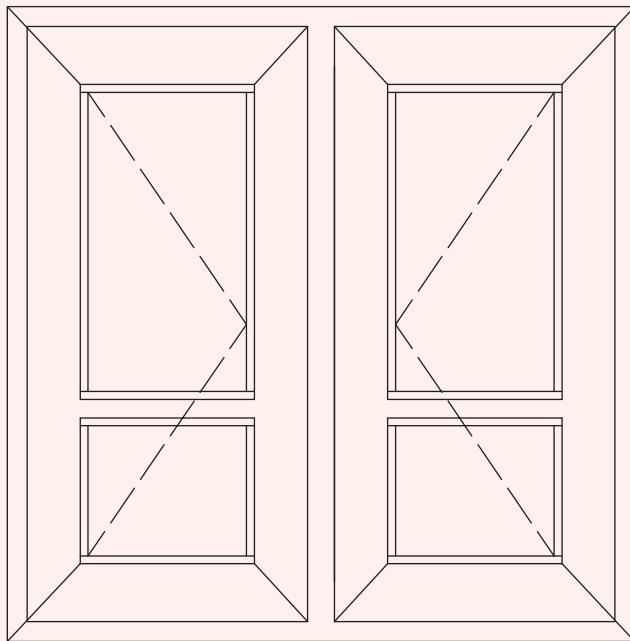

A

B

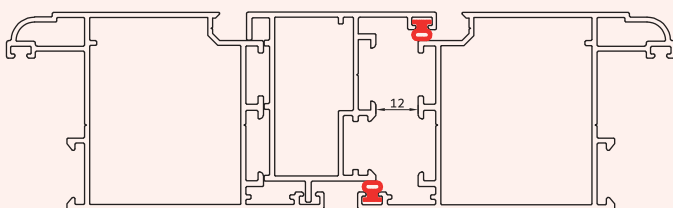
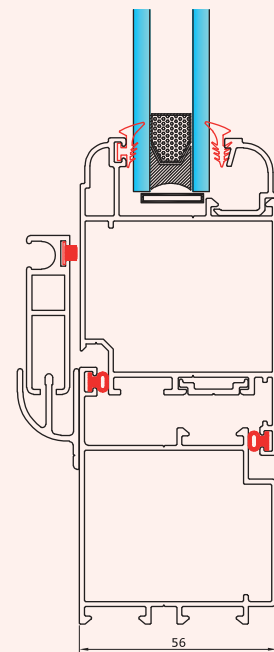
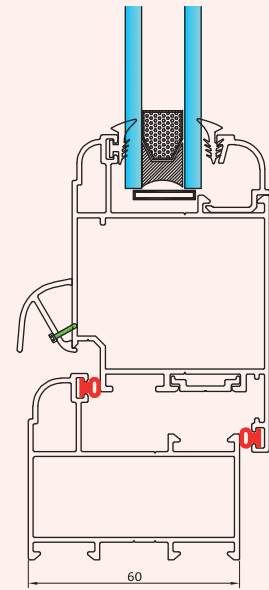

درب لولایی سری ۵۰

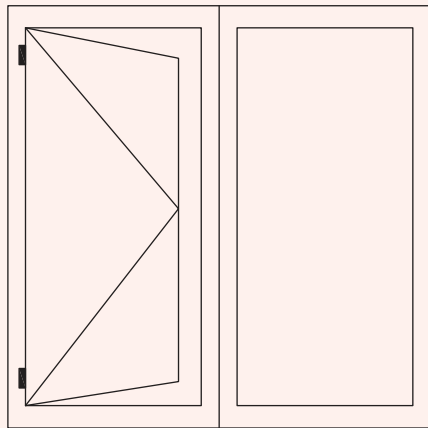

B

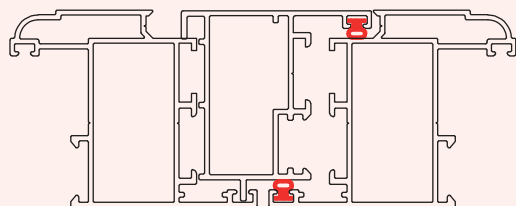
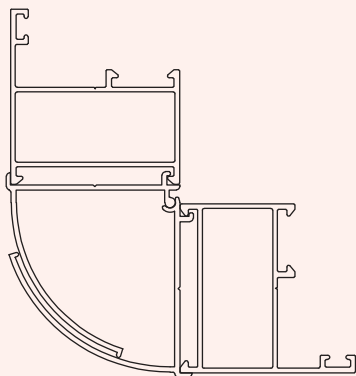
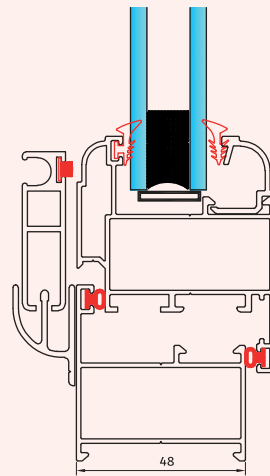
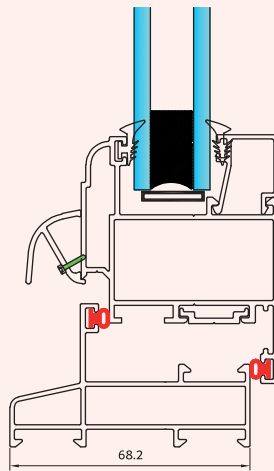
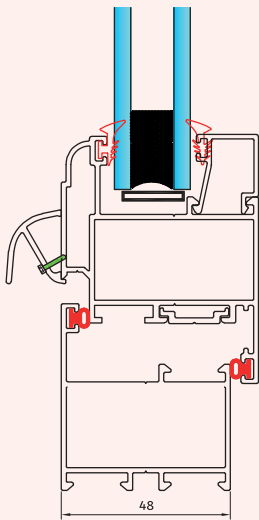
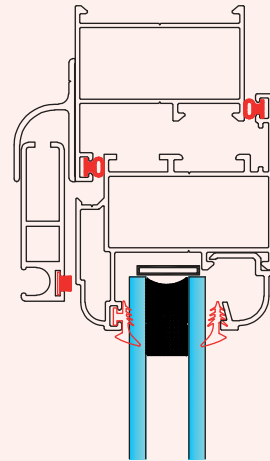

پنجره لولابی سری ۵۰

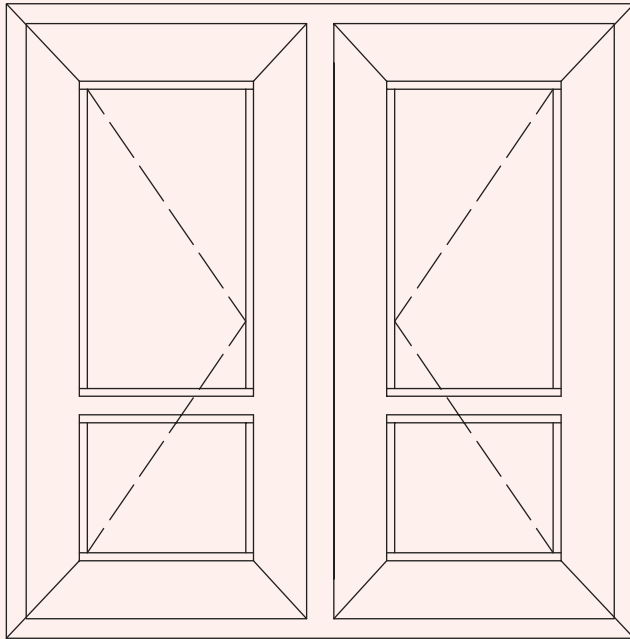

A

B

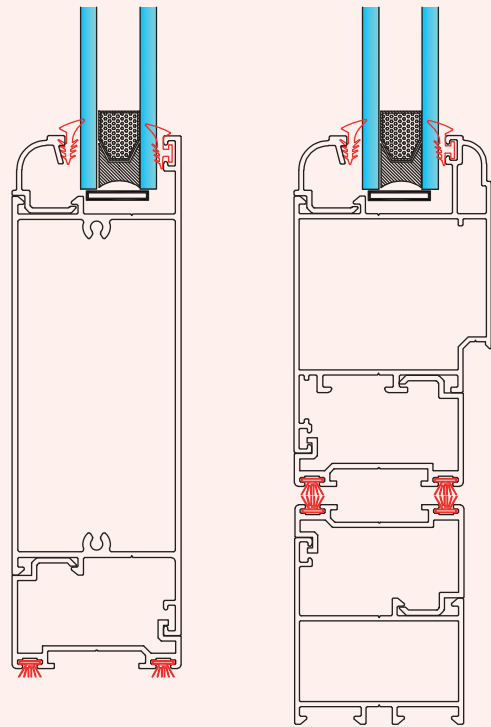

درب بدون آستانه

درب تک لنگه بادبزی

درب دو لنگه بادبزی

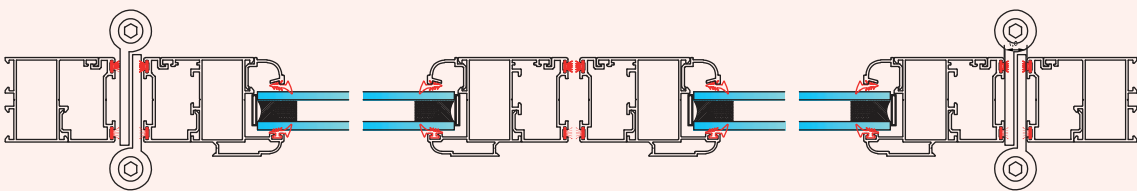

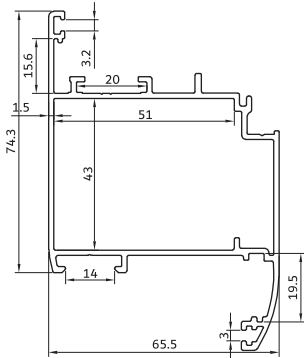

es-1201 لنگه در ۶۰
1370 gr/m vent profiles

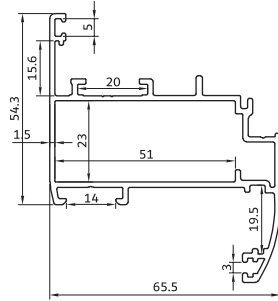

es-1200 لنگه پنجره ۶۰
1200 gr/m vent profiles

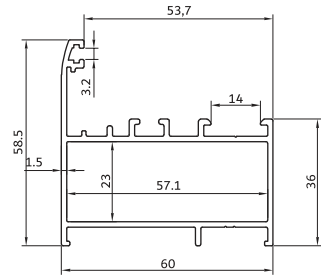

es-1250 چهارچوب لولایی ۶۰
1020 gr/m frame profiles

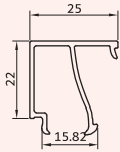

es-6100.tr زهوار دوجداره تخت
290 gr/m glass holder

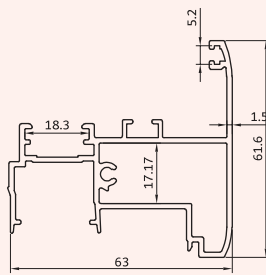

es-1249 دماغه متحرک دو لنگه بازشو
1100 gr/m the middle vent profiles

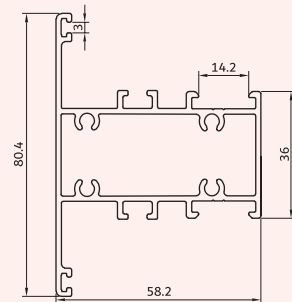

es-1400 سپری لولایی ۶۰
1300 gr/m tripetalous profiles

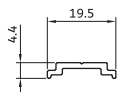

es-515 تسمه رابط
100 gr/m Strap profiles

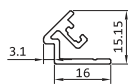

es-519 آداپتور لوله کنج
180 gr/m Rotating frame

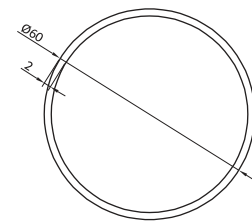

Ka-60 لوله محور کج
980 gr/m axial tube

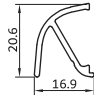

KA-510

آبچکان لنگه

220 gr/m

Water fropper profilis

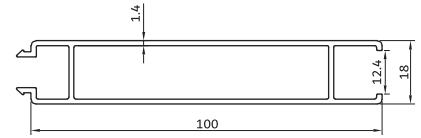

KA-521

فاساد دو جداره

930 gr/m

Double sheet

درب لولایی سری نرمال ۶۰ تی

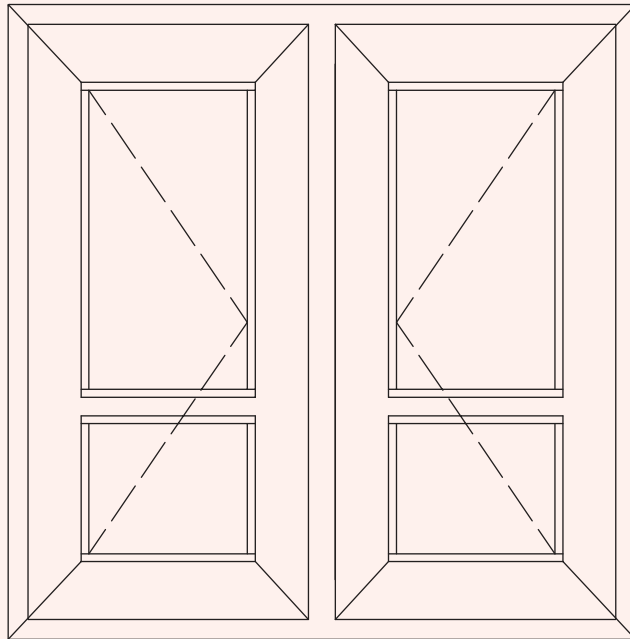

A

B

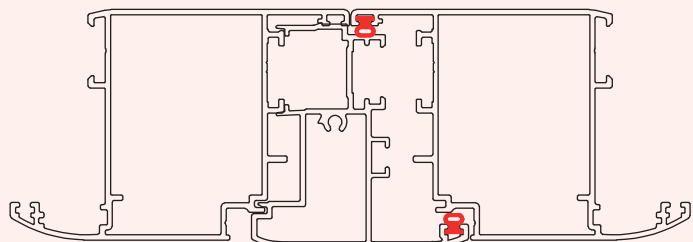
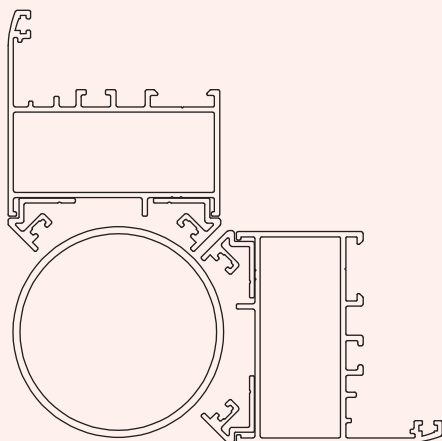
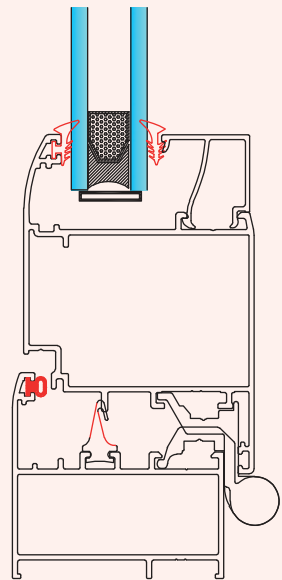

درب لولایی سری نرمال ۶۰ تی

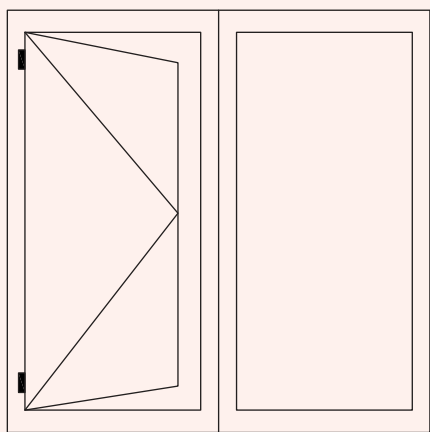

A

B

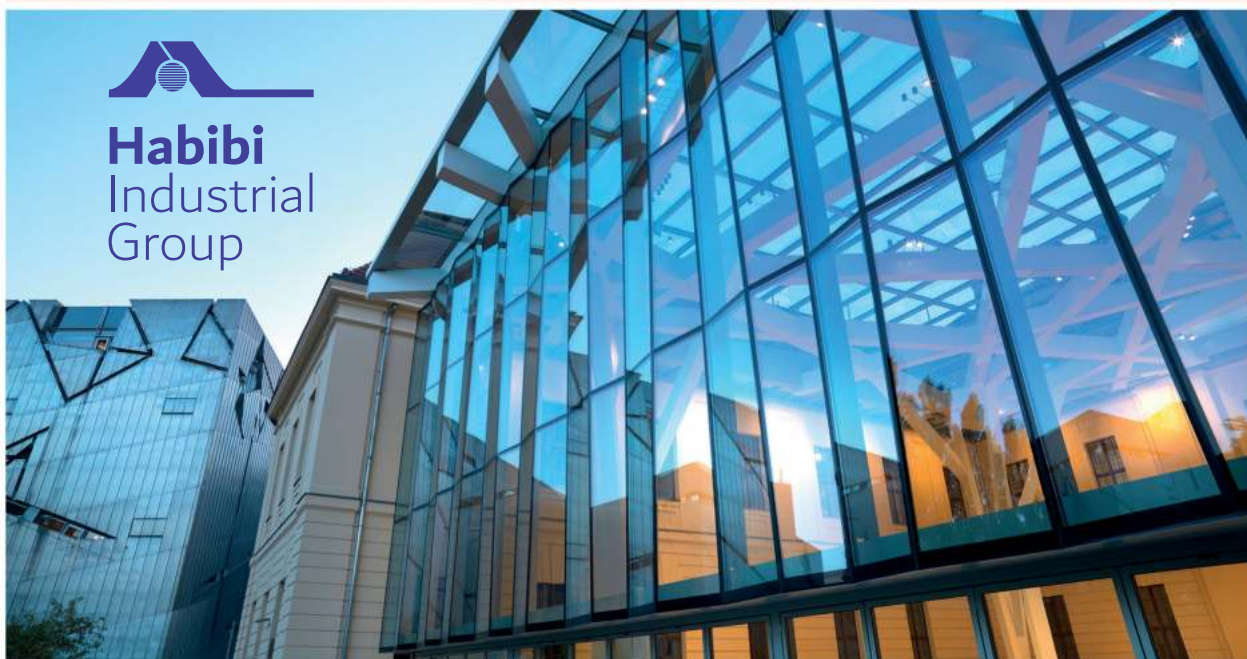
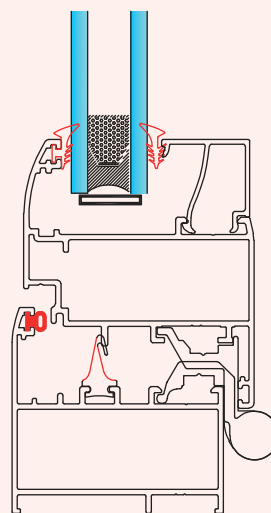
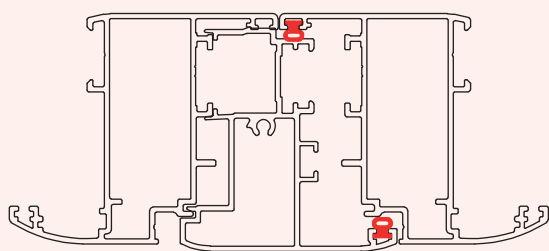

Habibi
Industrial
Group

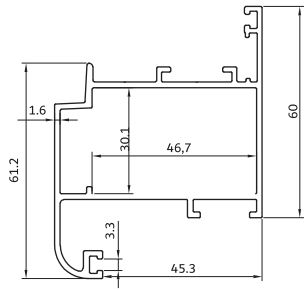

KA-05

1240 gr/m

لنگه در لولایی ۵۰

vent profilis

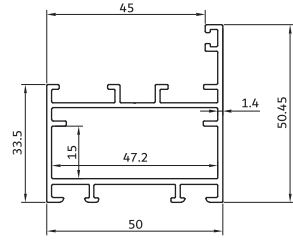

KA-02

920 gr/m

چهارچوب لولایی ۵۰

farme profilis

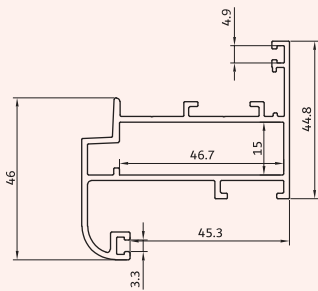

KA-04

1095 gr/m

لنگه پنجره لولایی ۵۰

vent profilis

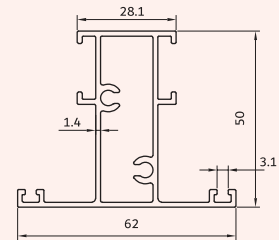

KA-03

950 gr/m

سپری لولایی ۵۰

tripetalous profilis

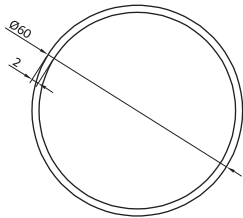

KA-60

980 gr/m

لوله محور کنج

axial tube

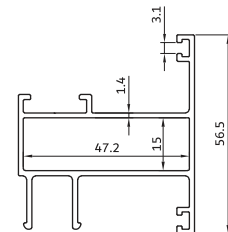

KA-08

896 gr/m

دماغه متحرک دولنگه بازشو

the middle vent profilis



KA-01

210 gr/m

زهوار دوجداره گرد

glass holder

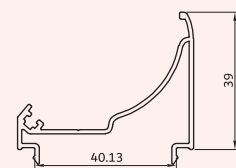

KA-09

460 gr/m

آداپتور کنج ۵۰

rotating frame profilis

پنجره لولایی سری - پنج هزار نرمال

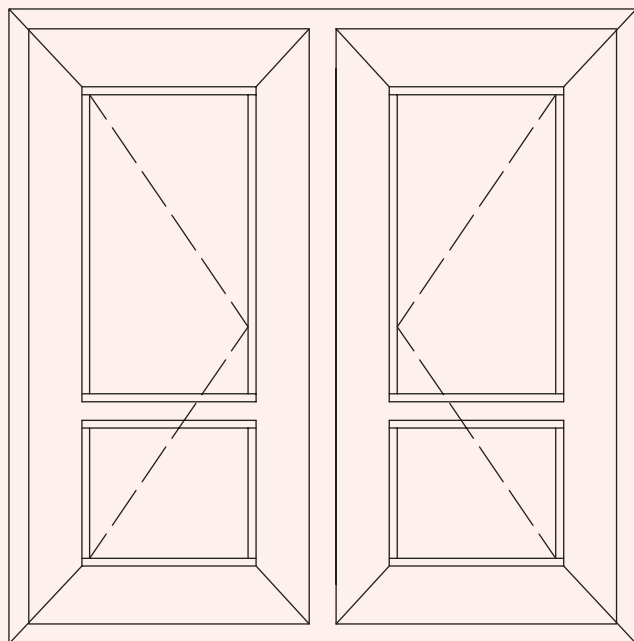

A

B

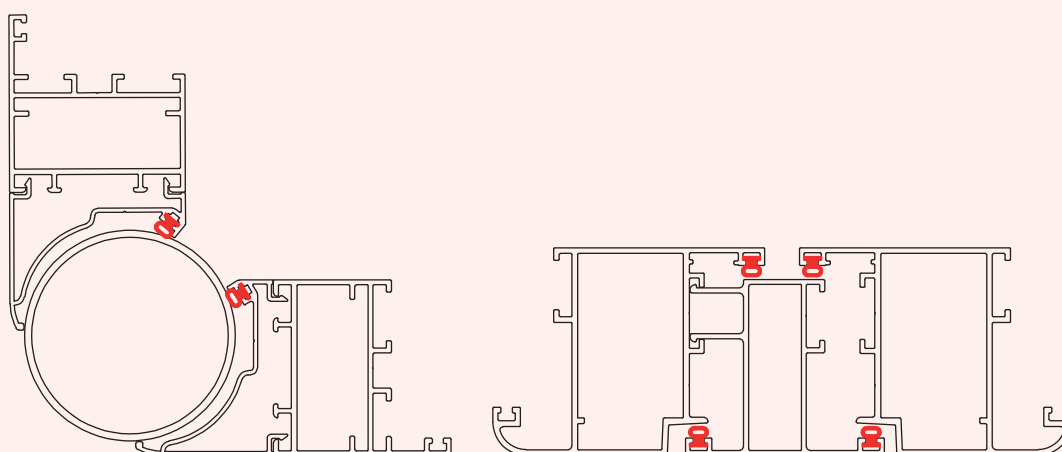
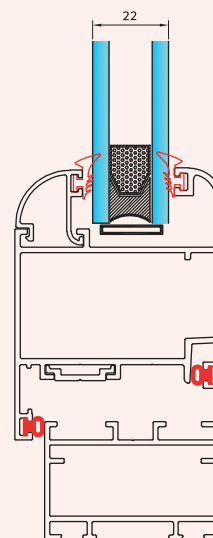

پنجره لولایی سری - پنج هزار نرمال

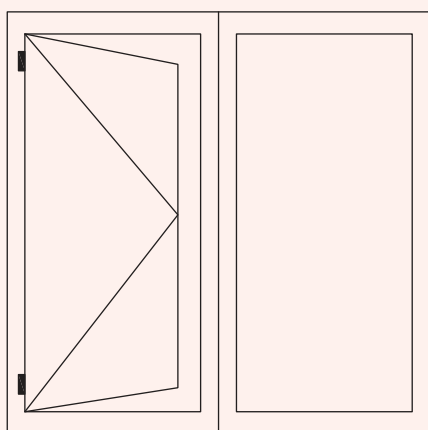

A

B

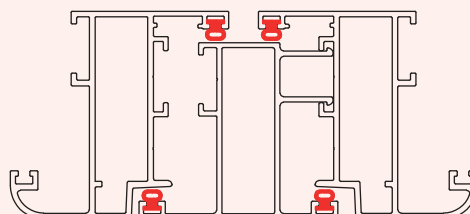
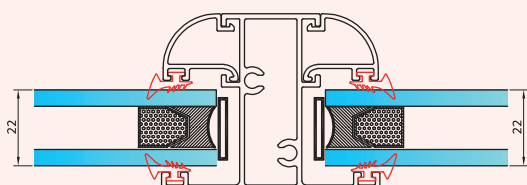
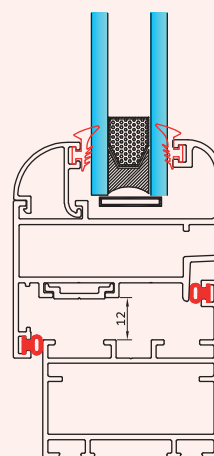

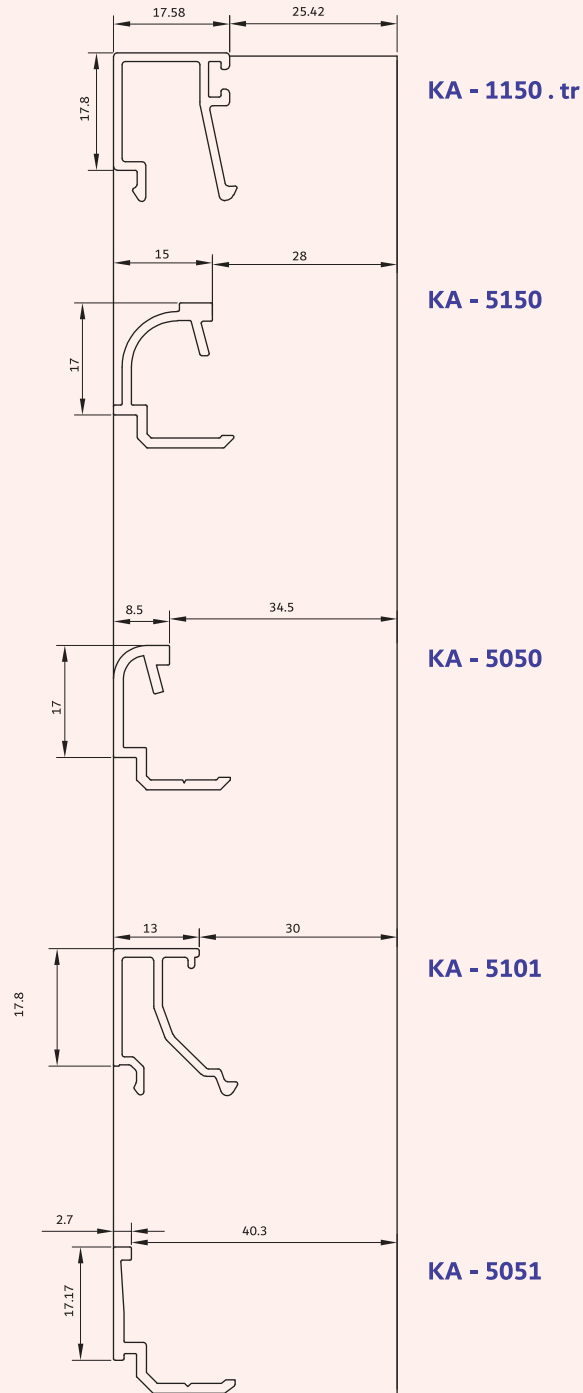

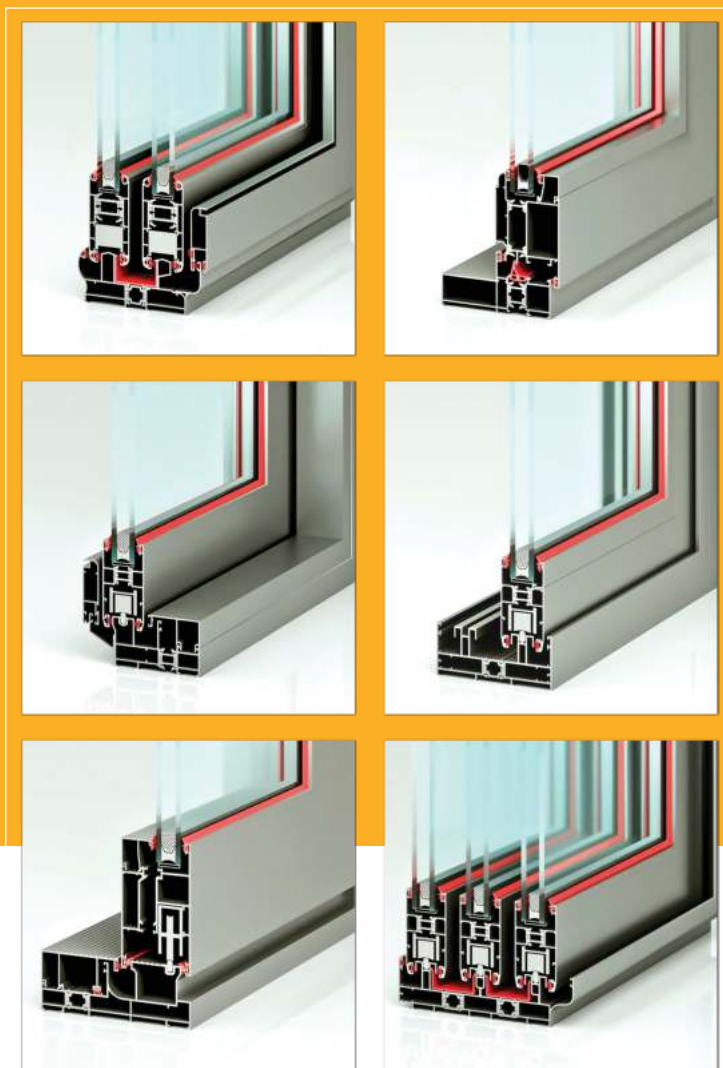

Thermal break
کشویی ترمال بریک

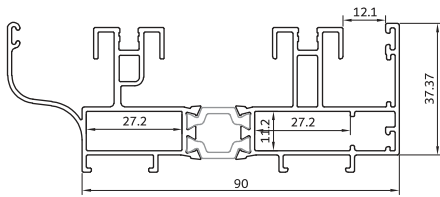

**KA-1252 / 2.tr**

چهارچوب کشویی لبه دار

1816 gr/m

Rail grid with frame

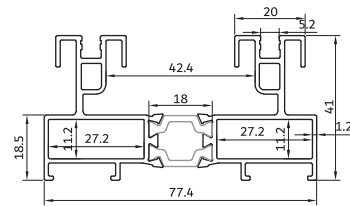
**KA-1252.tr**

چهارچوب کشویی ساده

1440 gr/m

Profiles frame simpel

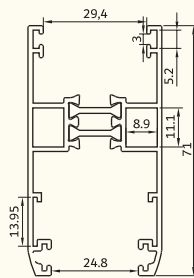
**KA-1202 / 1.tr**

لنگه کشویی زهوار سرخود

1160 gr/m

vent profiles

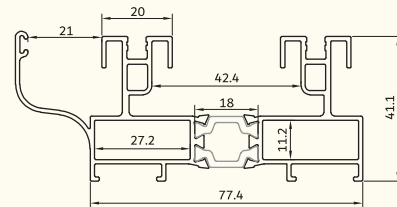
**KA-1252 / 1.tr**

چهارچوب کشویی توری خور

1680 gr/m

Rail grid with frame

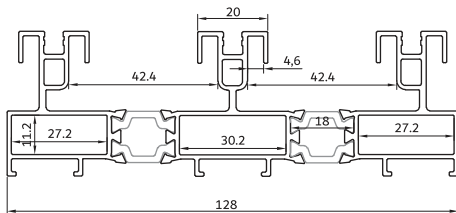
**KA-1252 / 3.tr**

چهارچوب کشویی سه ریل

2300 gr/m

3Rail grid with frame

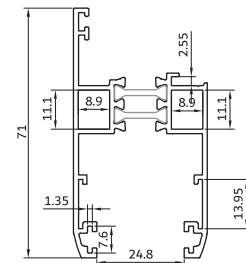
**KA-1202 / 2.tr**

لنگه کشویی زهوار خور

1070 gr/m

vent profiles

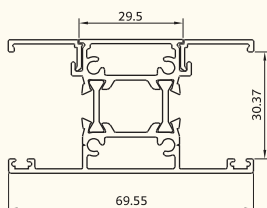
**KA-1402 / 2.tr**

سپری کشویی زهوارخور

1080gr/m

Tripetalous profiles

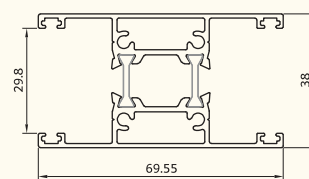
**KA-1402 / 1.tr**

سپری کشویی زهوار سرخود

1210gr/m

Tripetalous profiles

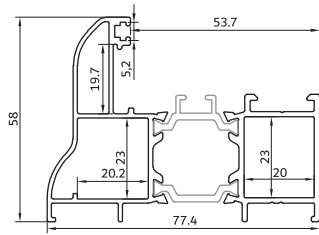

KA-1253.tr

1460 gr/m

چهارچوب لولایی هفتاد
frame profile great

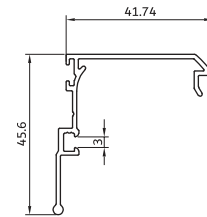

KA-516.tr

467 gr/m

درپوش لنگه کشویی
Gap

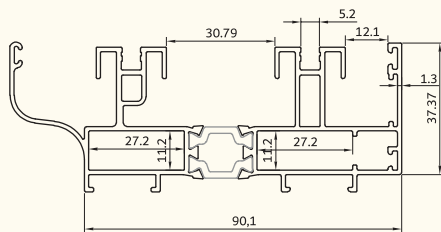

KA-1252 / 2.tr

1816 gr/m

چهارچوب کشویی لبه دار
Rail grid with frame

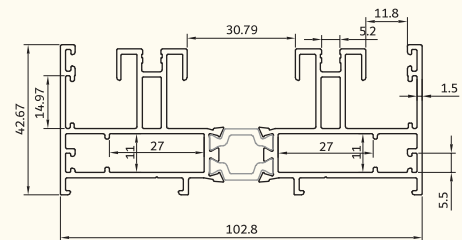

KA-1252 / 4.tr

2140 gr/m

چهارچوب کشویی دوطرف صاف
Rail grid with frame

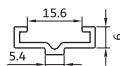

KA - 517 / 1

160 gr/m

زیرتسمه
Strap instead

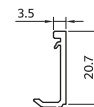

KA - 1102 / 1.tr

125 gr/m

زهوارکشویی
glass holder



KA - 509

140 gr/m

لوبیایی بلبرینگ
Rail for under wheel ballbearings



es - 515

100 gr/m

تسمه رابط
Strap profiles

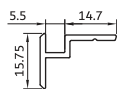
**KA - 514**

160 gr/m

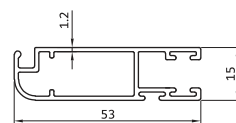
زهوار بین فریم
adaptor profiles**KA - 539**

510 gr/m

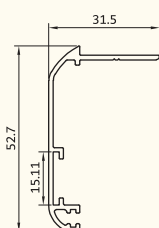
فریم توری کشویی
Grid vent**KA - 452**

398 gr/m

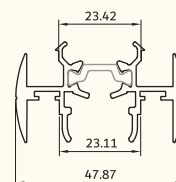
روکوب پنجاه و دو
Suppressed the bilding**KA - 513.tr**

756 gr/m

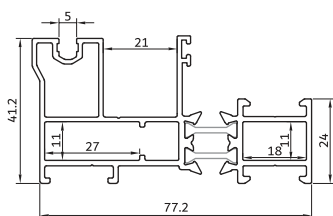
زهوار چهار لنگه
The middle four vent**KA - 7754.tr**

1460 gr/m

چهار چوب تک ریل
Rail grid with frame**es - 501**

2550 gr/m

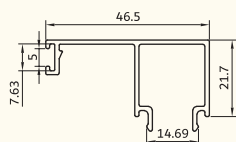
گونیا ده
Fixer**KA - 7754**

400 gr/m

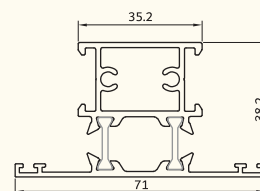
درپوش فریم تک ریل
Slidin fix cap**KA - 7740.tr**

1160 gr/m

سپری تک ریل کشویی
Tripetalous profiles

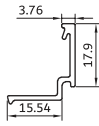

KA - 7756 زهوار فریم و سپری تک ریل
170 gr/m glass holder

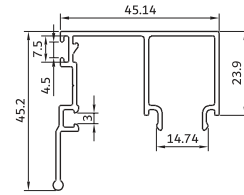

KA - 7755 درپوش سپری تک ریل
590 gr/m Gap

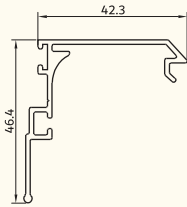

KA - 516.tr درپوش لنگه کشویی
467 gr/m Gap

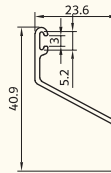

KA - 7757 ریل توری تک ریل
250 gr/m Grid rails

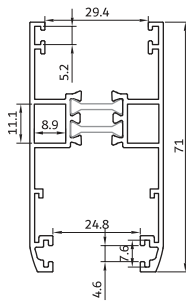

KA - 1202 / 1.tr لنگه کشویی زهوار سرخود
1160 gr/m vent profiles

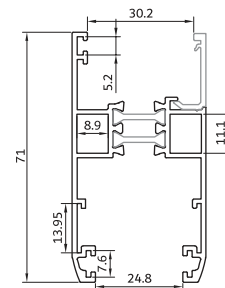

KA - 1202 / 2.tr لنگه کشویی زهوار خور
1060 gr/m vent profiles



KA - 509 لوبیایی بلبرینگ
140 gr/m Rail for under wheel ball bearings

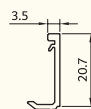

KA - 1102 / 1.tr زهوار کشویی
125 gr/m glass holder

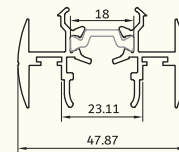

KA - 513.tr زهوار چهار لنگه
756 gr/m The middle four vent

پنجره کشویی ترمال بریک

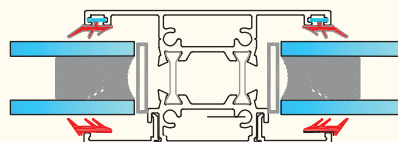
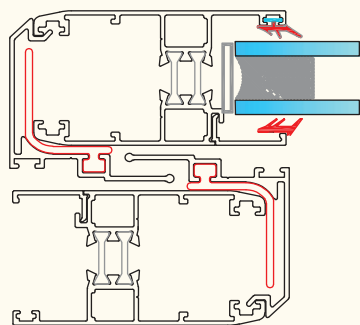
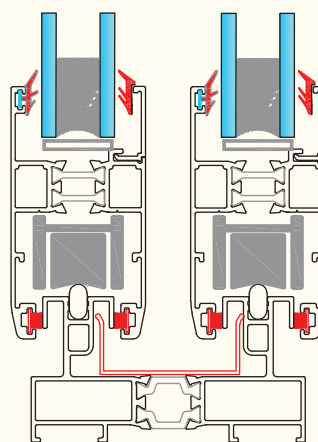
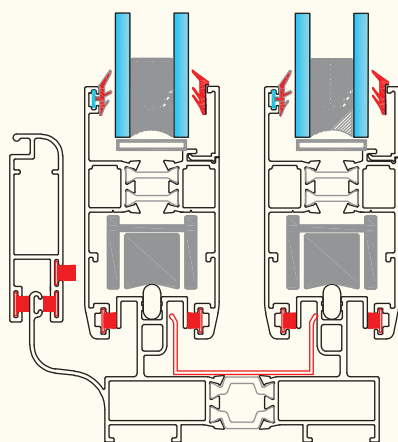
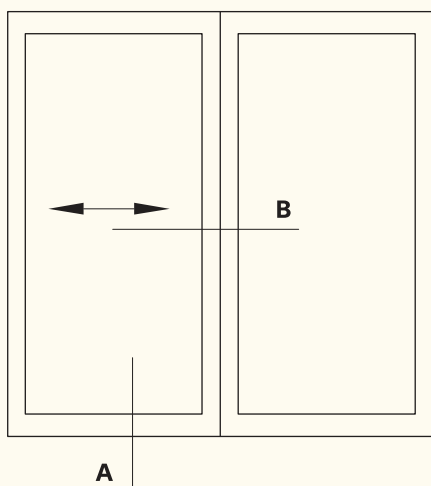

پنجره کشویی ترمال بریک لبه دار

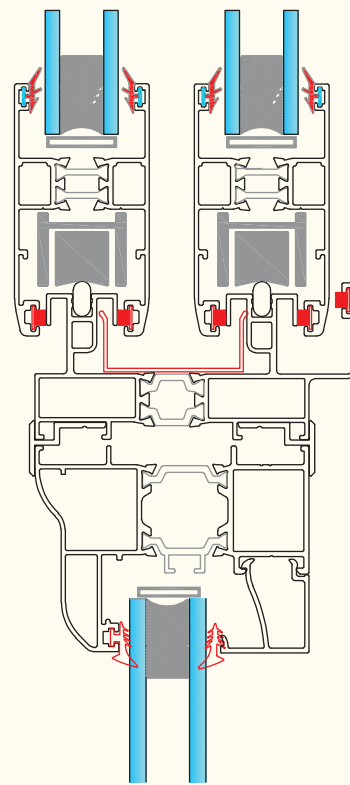
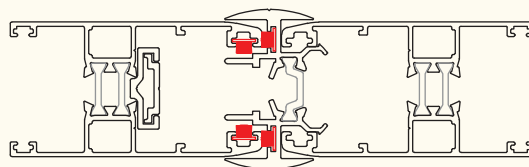
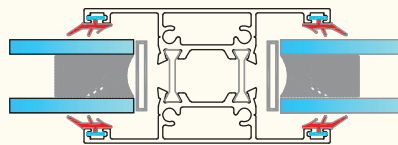
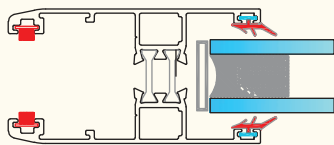
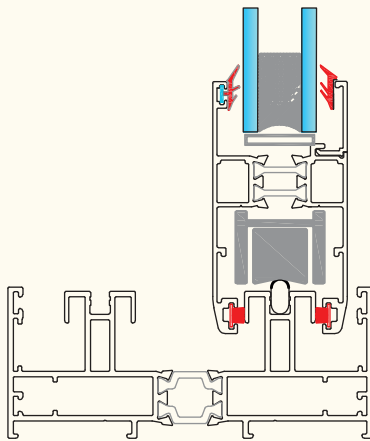
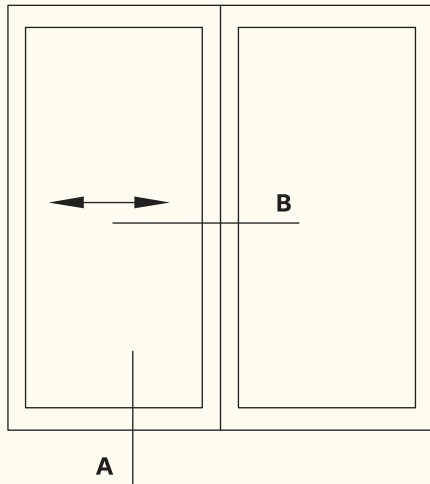

پنجره کشویی ترمال بربک سه ریل سری

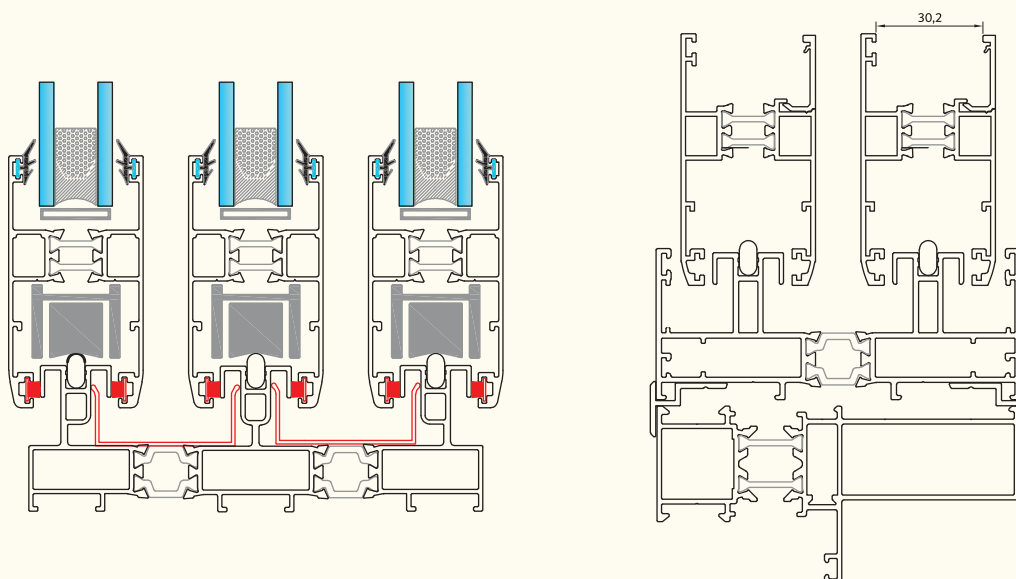
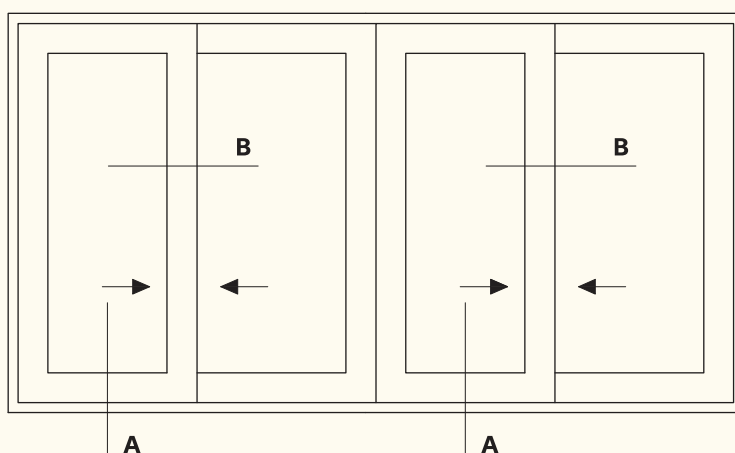

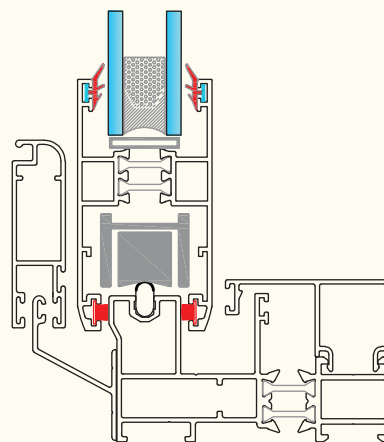
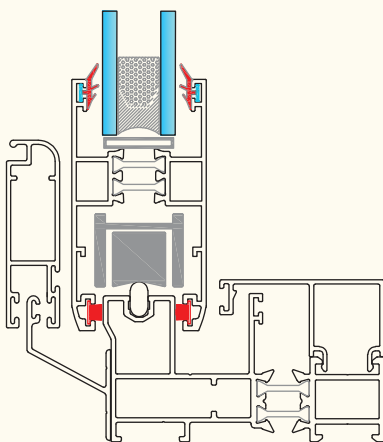
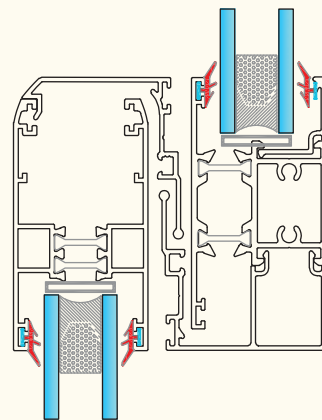
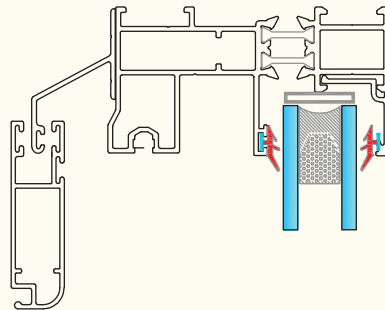
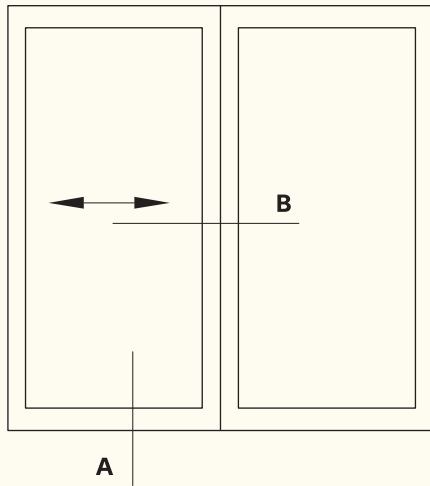

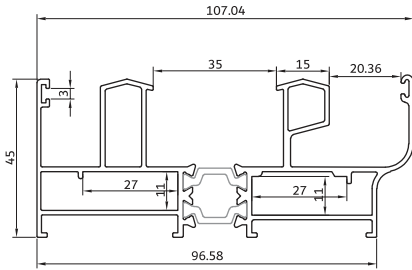

KA - 3252 / 1.tr

1914gr/m

چهار چوب کشویی توری خور

Rail grid with frame

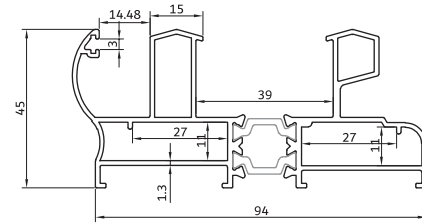

KA - 3252.tr

1725gr/m

چهار چوب کشویی ساده

Profiles frame simpel

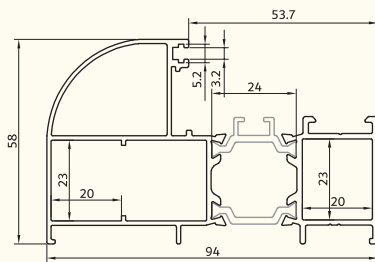

KA - 3253.tr

1773gr/m

چهار چوب کتیبه نود و چهار

frame profile great

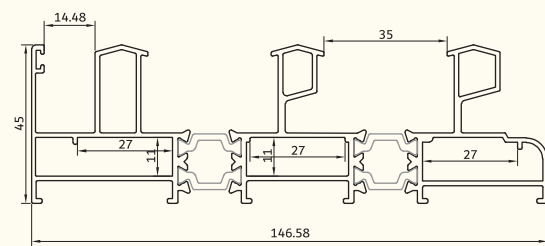

KA - 3252 / 3.tr

2590gr/m

چهار چوب کشویی سه ریل

3Rail grid wth frame

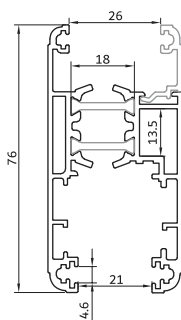

KA - 3202 / 1.tr

1430gr/m

لنگه کشویی زهوار خور

vent profils

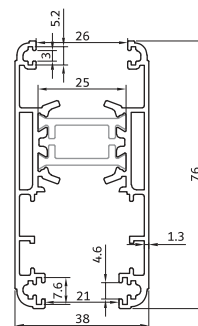

KA - 3202.tr

1587gr/m

لنگه کشویی زهوار سرخود

vent profils

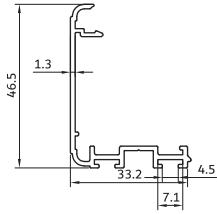
**KA - 3516.tr**

427 gr/m

درپوش لنگه کشویی

gap

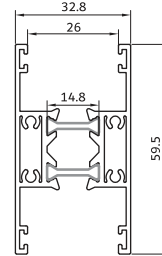
**KA - 3402.tr**

1050 gr/m

سپری لنگه کشویی

tripetalous profiles

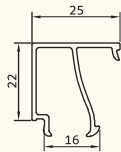
**es - 6100/tr**

290 gr/m

زهوار دو جداره تخت

glass holder

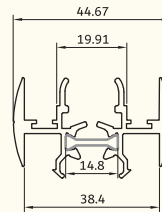
**KA - 513.tr**

756 gr/m

زهوار چهار لنگه کشویی

the middle four vent

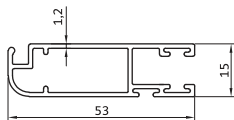
**KA - 539**

510 gr/m

فریم توری کشویی

grid vent

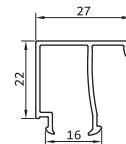
**KA - 4102.tr**

285 gr/m

زهوار دو جداره تخت

glass holder

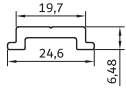

KA - 3515.tr تسمه رابط ۹۴
155 gr/m strap profiles

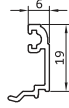

KA - 3102.tr زهوار کشویی ۹۴
155 gr/m glass holder

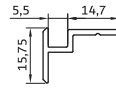

KA - 514 زهوار بین فریم
160 gr/m adaptor profiles

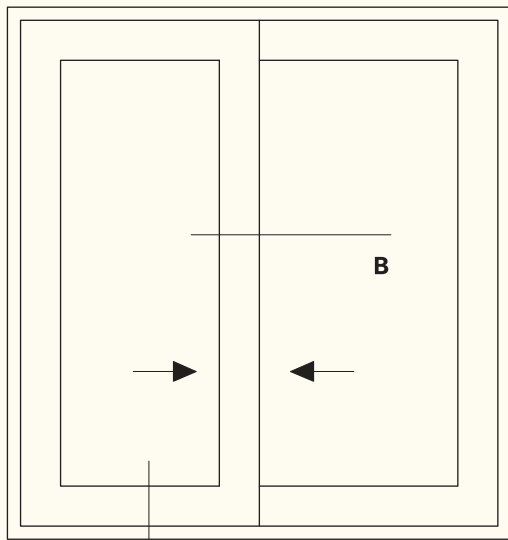

A

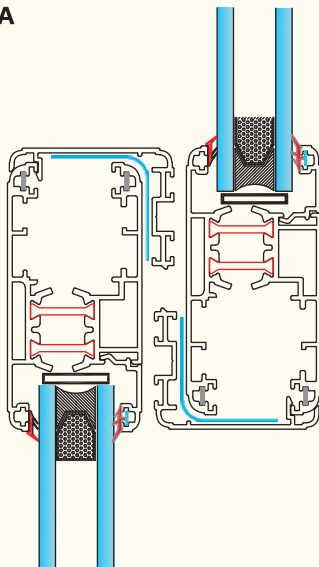

پنجره کشویی ترمال بریک

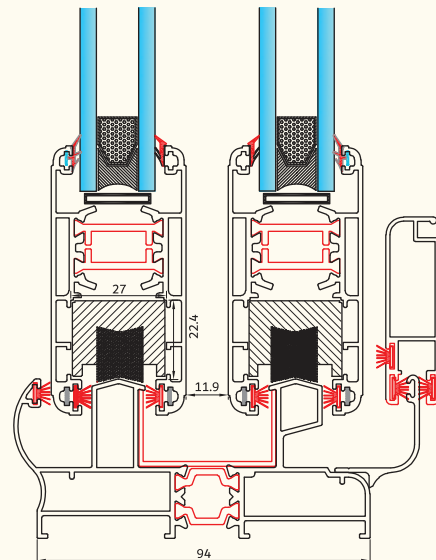
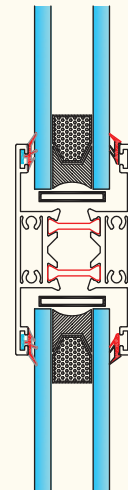

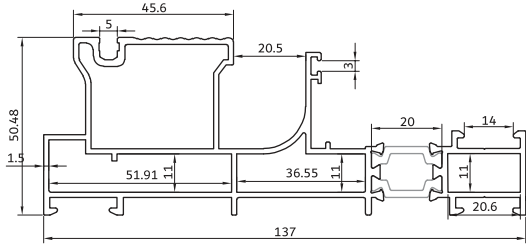

KA - 4254.tr

چهار چوب کشویی تک ریل

2500 gr/m

rail grid with frame

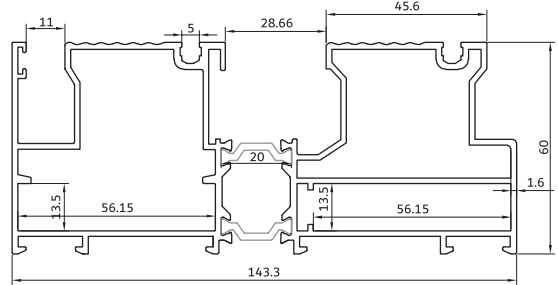

KA - 4252.tr

چهار چوب کشویی دو ریل

3400 gr/m

rail grid with frame

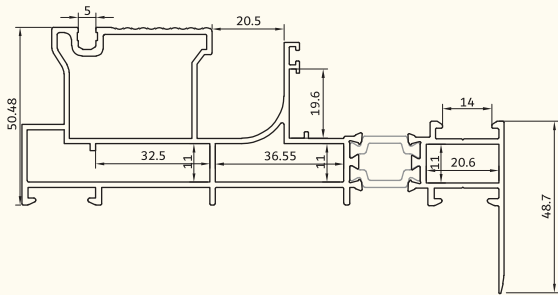

KA - 4254/1.tr

چهار چوب کشویی تک ریل روکوبدار

2700 gr/m

rail grid with frame

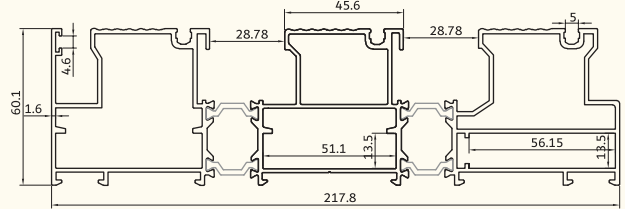

KA - 4252/3.tr

چهار چوب کشویی سه ریل

5000 gr/m

3 rail grid with frame

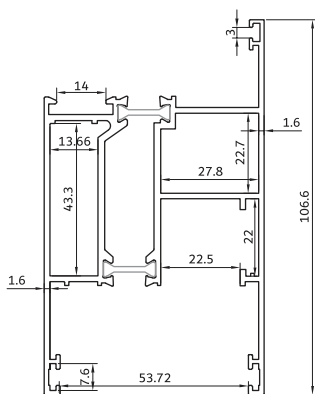

KA - 4202.tr

لنگه کشویی و لیفت

2200 gr/m

vent profiles

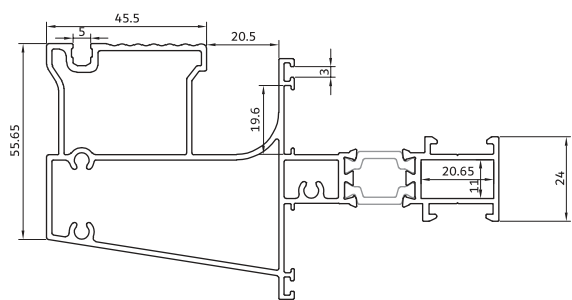

KA - 4256.tr

کتیبه منو ریل

2490 gr/m

engraving profile

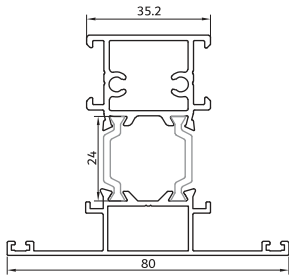
**KA-4402.tr**

1480 gr/m

سپری لنگه کشویی

Tripetalous profilis

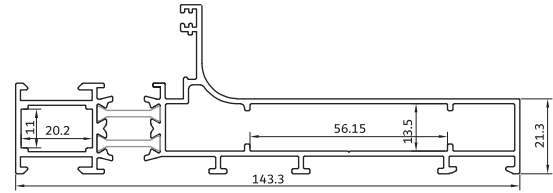
**KA - 4253.tr**

1480 gr/m

چهار چوب کتیبه

frame profile great

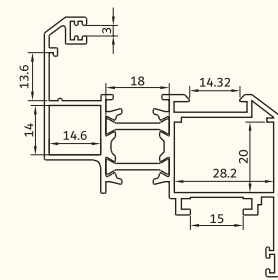
**KA-4200.tr**

1480 gr/m

لنگه لولایی کتیبه

vent profilis

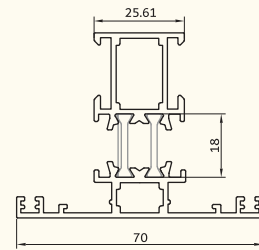
**KA-4400.tr**

1350 gr/m

سپری کتیبه

Tripetalous profilis

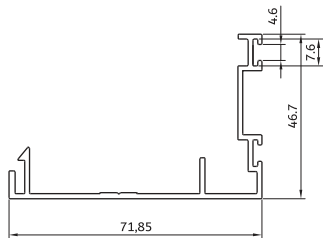
**KA-416.tr**

700 gr/m

درپوش لنگه کشویی

Gap

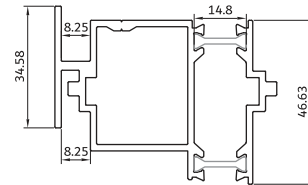
**KA-4249.tr**

1600 gr/m

دماغه چهار لنگه کشویی

The middle four vent

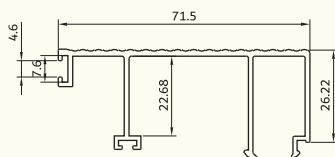
**KA-454**

800 gr/m

درپوش فریم تک ریل

Slidin fix cap

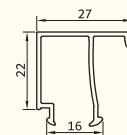
**KA-4102.tr**

285 gr/m

زهوار دوجداره

glass holder

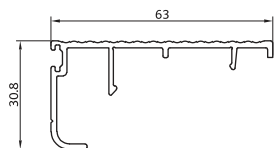
**KA-10515**

466 gr/m

درپوش بیرونی فریم

Slidin fix cap

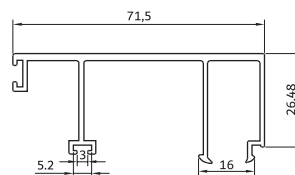
**KA-454 / 1**

800 gr/m

درپوش فریم تک ریل صاف

Slidin fix cap

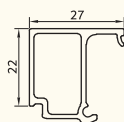
**KA-4127.tr**

365 gr/m

زهوار دو جداره

glass holder

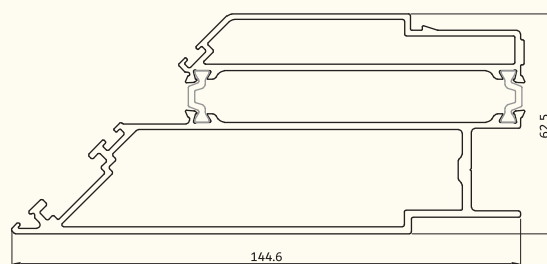
**KA-4203.tr**

3300 gr/m

پروفیل کنج نود درجه لنگه

corner profile

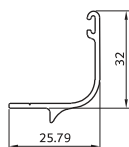
**KA-407**

215 gr/m

ریل توری کشویی

Grid rails

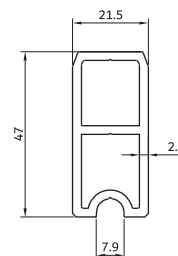
**KA-21074**

1054 gr/m

بالانسر لنگه

Balancer

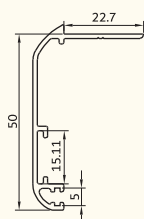
**KA-452**

400 gr/m

روکوب پنجاه و دو

Suppressed the bilding

**KA-509**

140 gr/m

لوبیایی بلبرینگ

Rail for undr wheel ballbearings

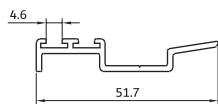

KA-418 درپوش لنگه وسط بازشو
355 gr/m Balancer

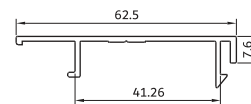

KA-417 درپوش لنگه وسط بازشو
430 gr/m Balancer

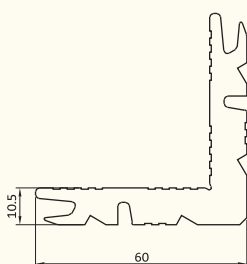

es-501 گونیا ده
2550 gr/m Fixer

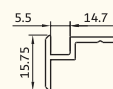

KA-514 زهوار بین فریم
160 gr/m frame profile great

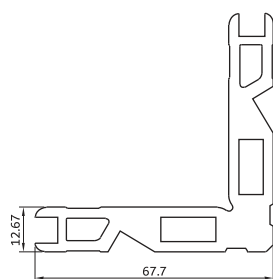

KA-506 گونیا ۱۳
2670 gr/m Fixer

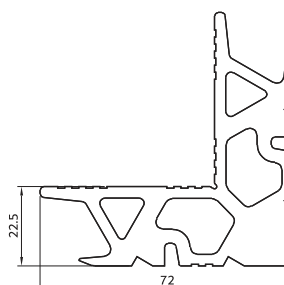

es-502 گونیا ۲۲
3700 gr/m Fixer

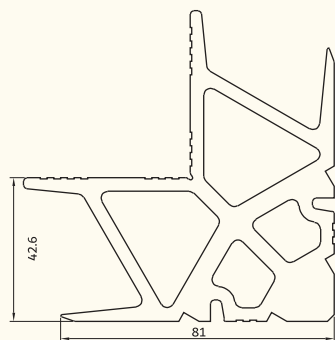

es-504 گونیا ۴۲
5650 gr/m Fixer



KA-404 لقمه سپری تک ریل
515 gr/m Fixer

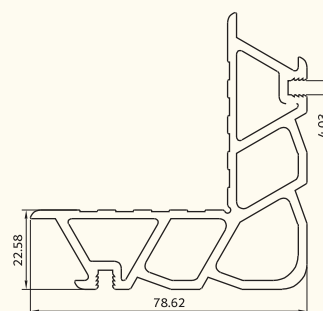

es-502 / 1 گونیا ۲۲ سبک
2700 gr/m Fixer

پنجره کشویی ترمال بریک

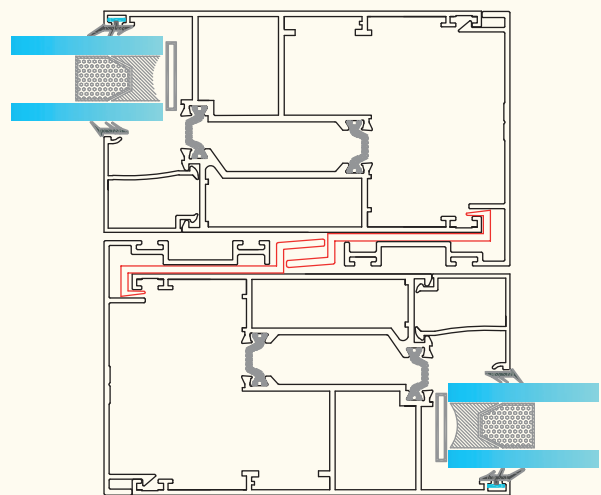
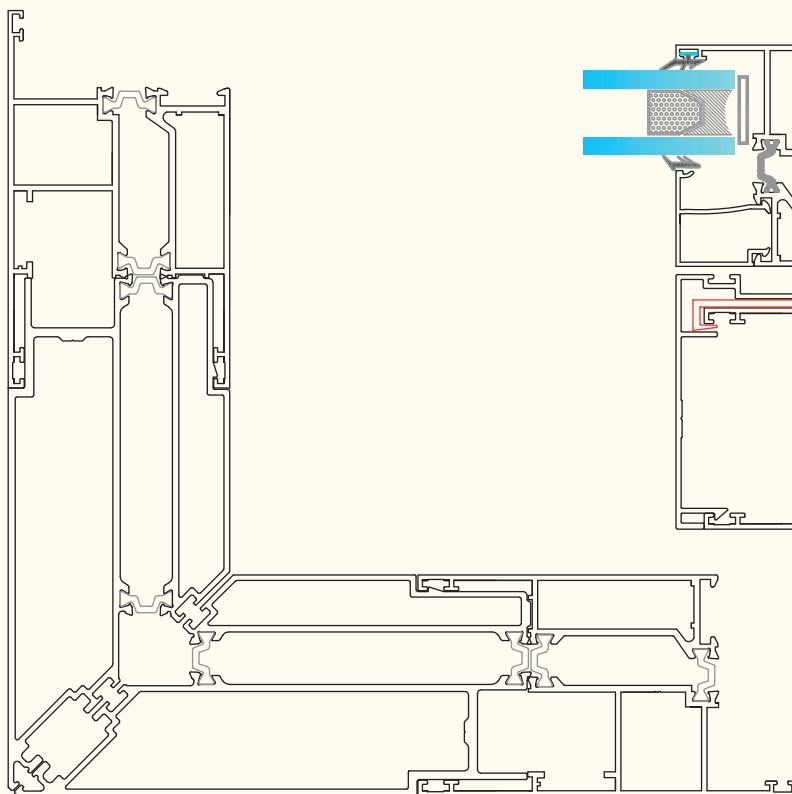
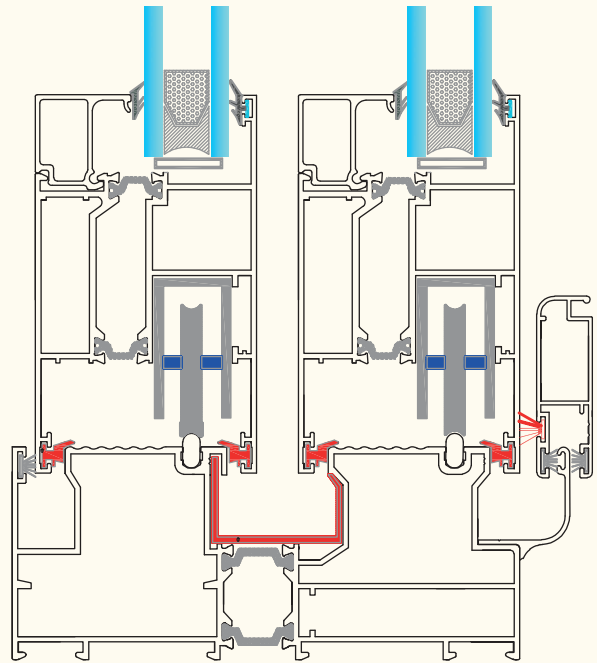
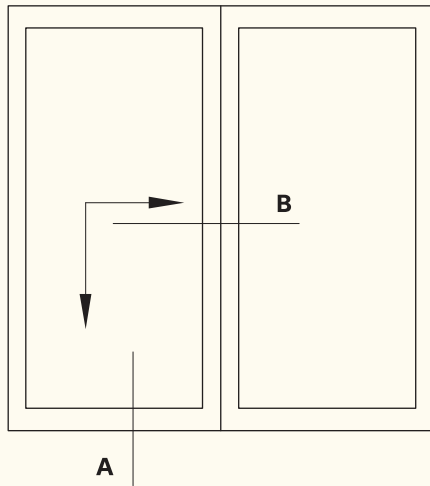

پنجره کشویی ترمال بریک

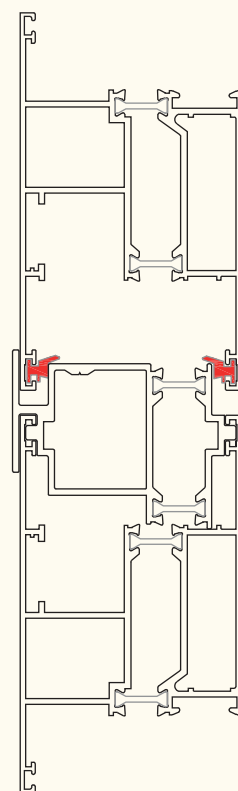
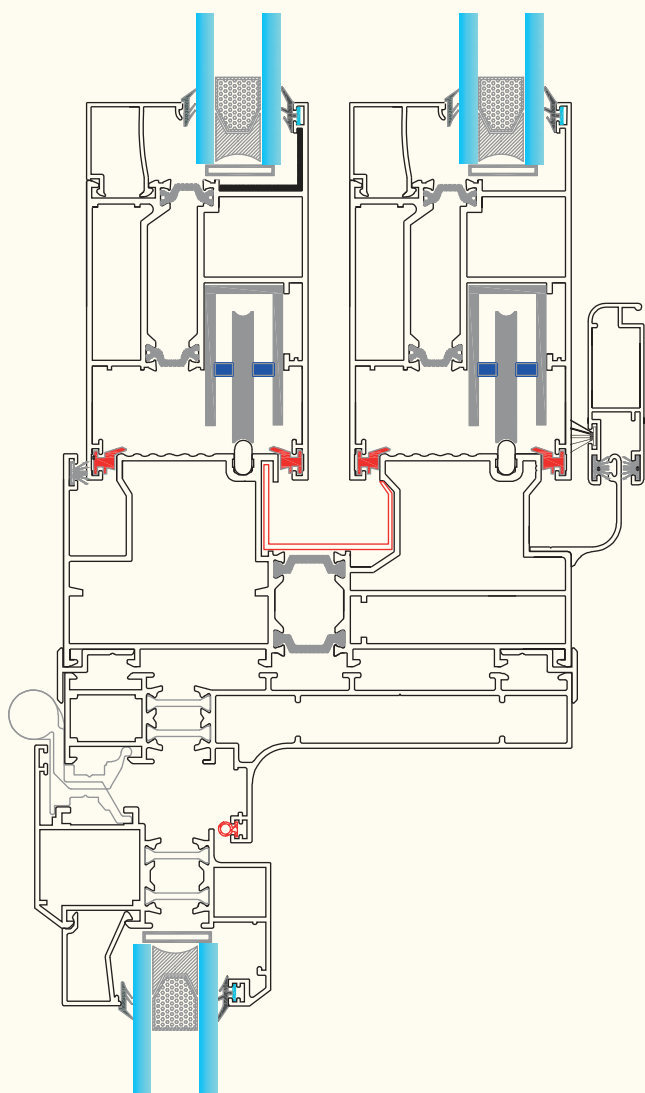
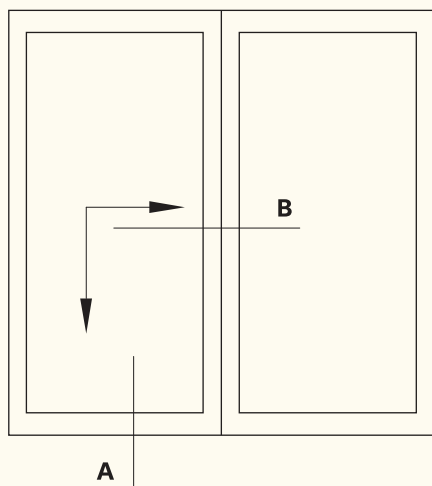

▶ پنجره کشویی ترمال بریک تک ریل

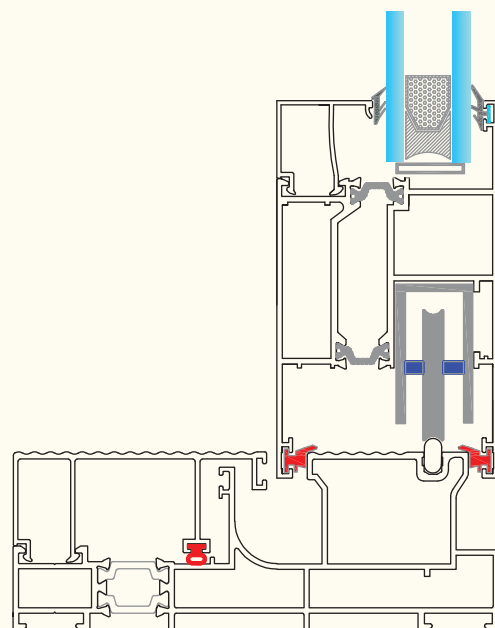
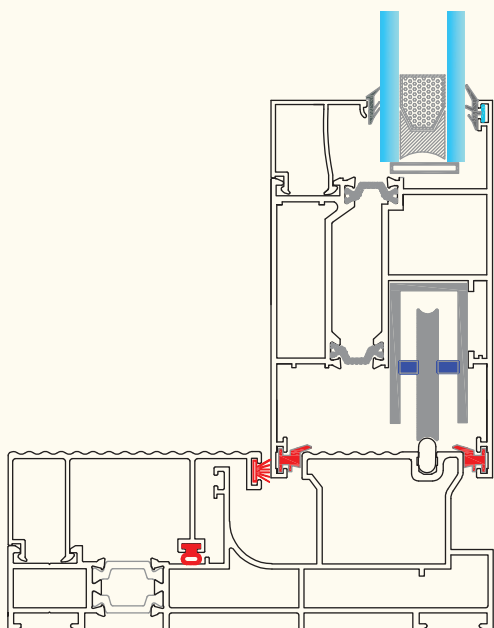
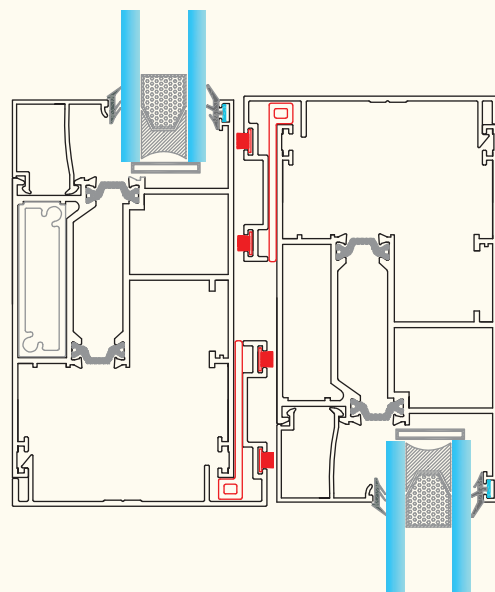
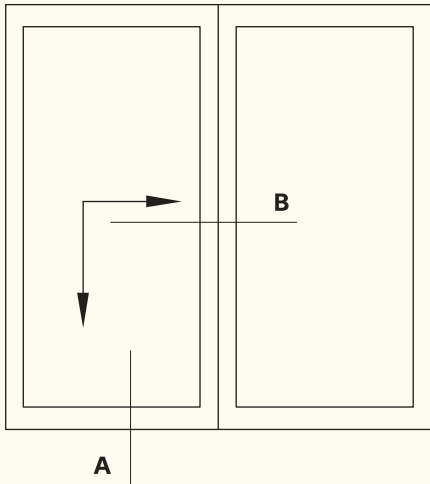

پنجره کشویی ترمال بریک تک ریل

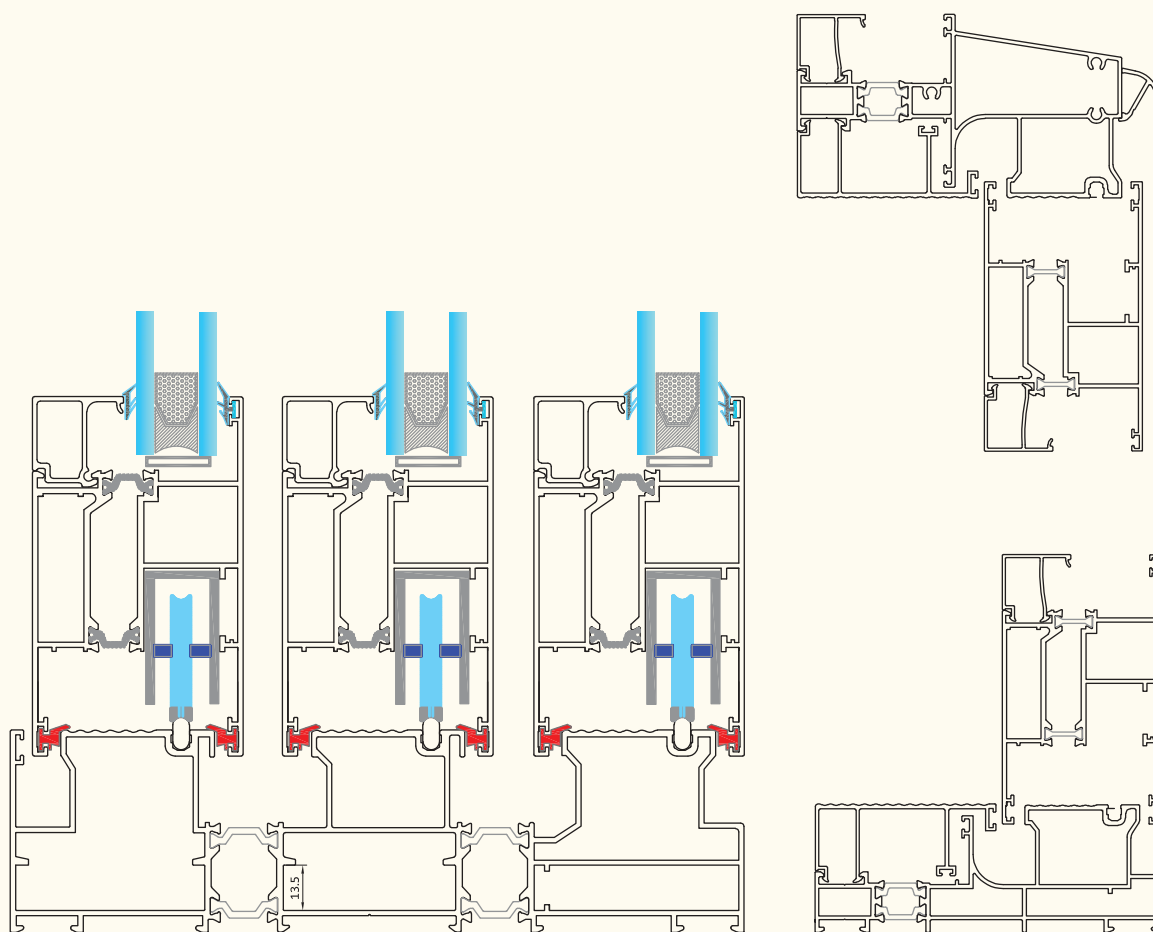
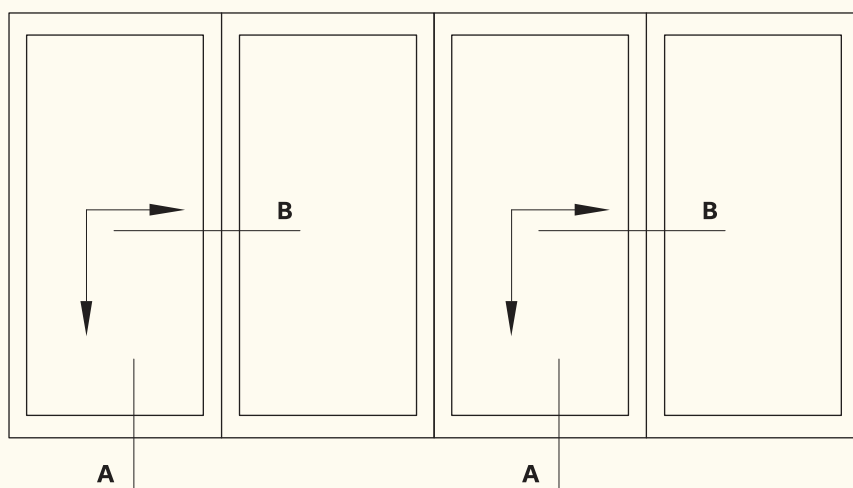



Habibi Industrial Group

Manufacturer of All Kinds of

DC Billet

Aluminum Sections

Powder Coating

Anodizing



Thermal break sliding door & window

کشویی ترمال بریک سری ۱۱۵

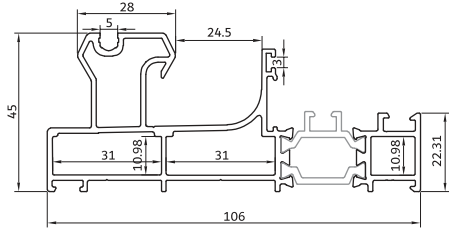

KA-14254.tr چهارچوب کشویی تک ریل
1810 gr/m Rail grid with frame

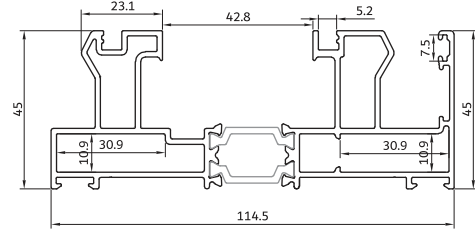

KA-14252.tr چهارچوب کشویی دو ریل
2250 gr/m Rail grid with frame

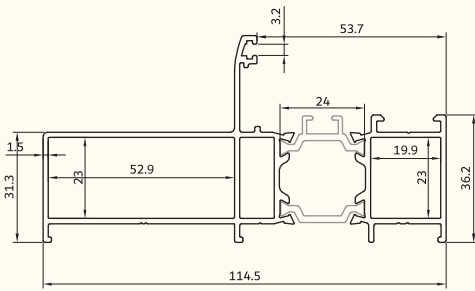

es-6255 / tr فریم کتیبه تقویتی
1862 gr/m Strengthened frame profiles

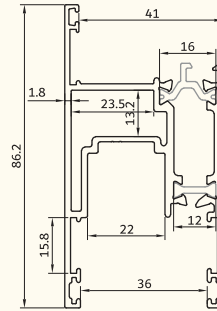

KA-14202.tr لنگه کشویی
10695 gr/m vent profiles

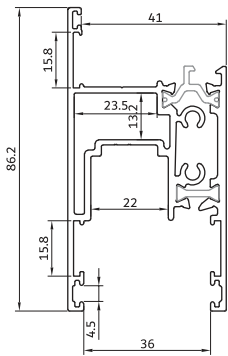

KA-14203.tr لنگه کشویی و سپری تک ریل
1850 gr/m vent profiles

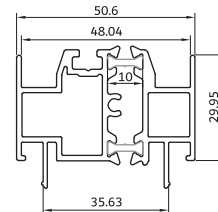

KA-14212.tr دماغه چهارلنگه کشویی
1250 gr/m The middle four vent

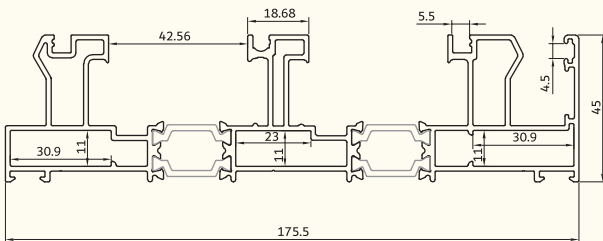

KA-14252./3tr چهار چوب کشویی دو ریل
3295gr/m 2 Rail grid with frame

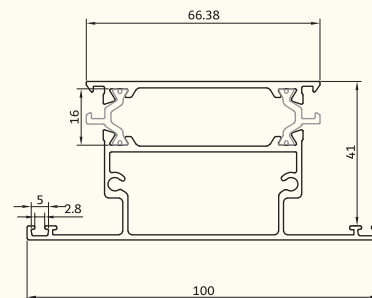

KA-14402.tr سپری لنگه کشویی
1600gr/m Tripetalius profiles

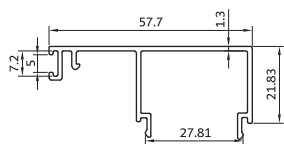

KA-14555 درپوش فریم تک ریل
460 gr/m Rail grid with frame

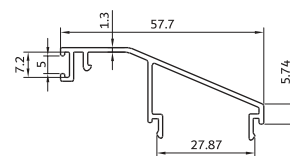

KA-14554 درپوش فریم تک ریل سمت دستگیره
413 gr/m Rail grid with frame



KA-14103.tr زهوار دوجداره
160gr/m glass holder

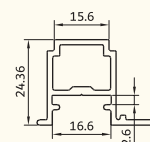

KA-14518.tr پروفیل نصب و تسمه دستگیره
445gr/m

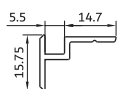

KA-514 زهوار بین فریم
160 gr/m frame profile great



KA-14102.tr زهوار دوجداره
195 gr/m glass holder



KA-509 لوبیایی بلبرینگ
140gr/m Rail for under wheel ballbearings

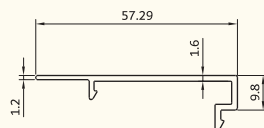

KA-14516.tr درپوش لنگه کشویی
335gr/m Gap



KA-202 تسمه پراق کشویی
105 gr/m strap profiles

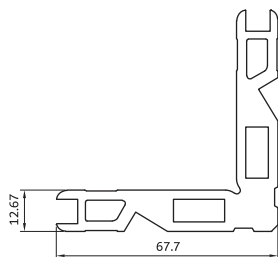

es-506

گونیا ۱۳

2670 gr/m

Fixer

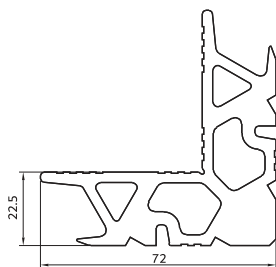

es-502

گونیا ۲۳

3700 gr/m

Fixer

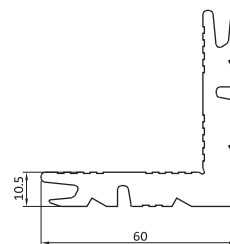

es-501

گونیا ده

2550 gr/m

Fixer

پنجره کشویی ترمال بریک

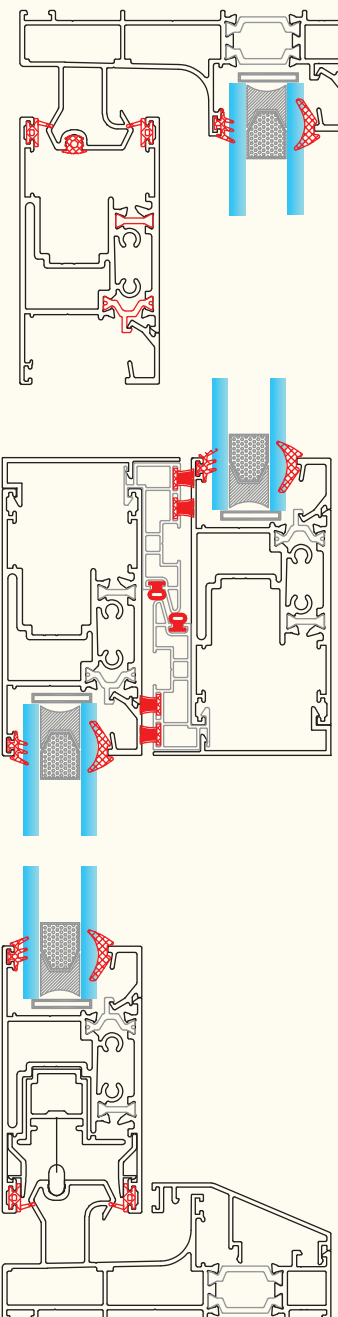
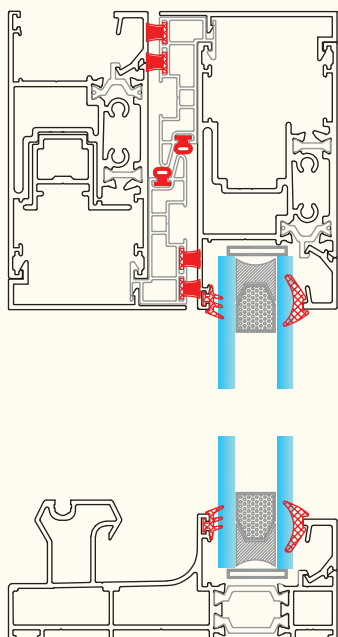
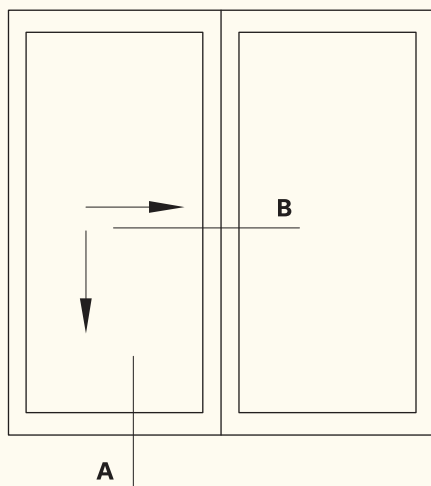

کشویی ترمال

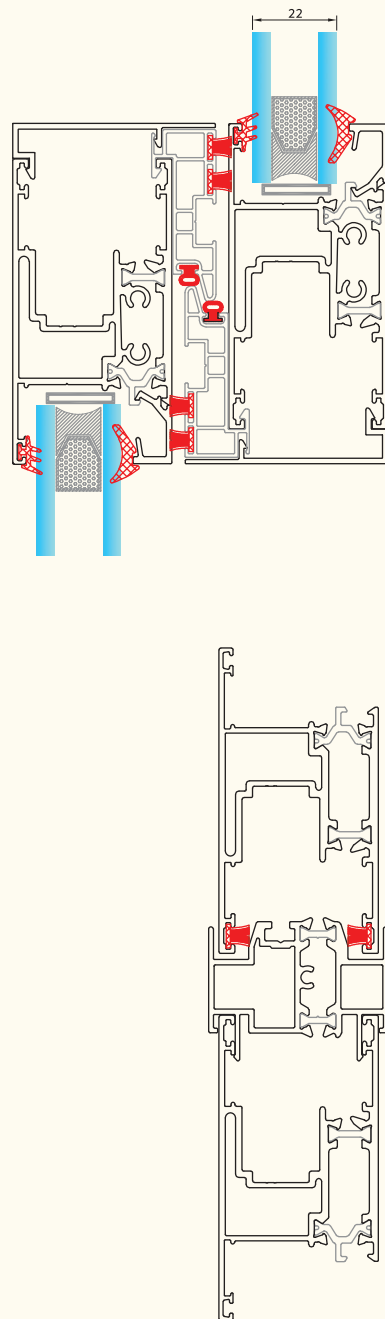
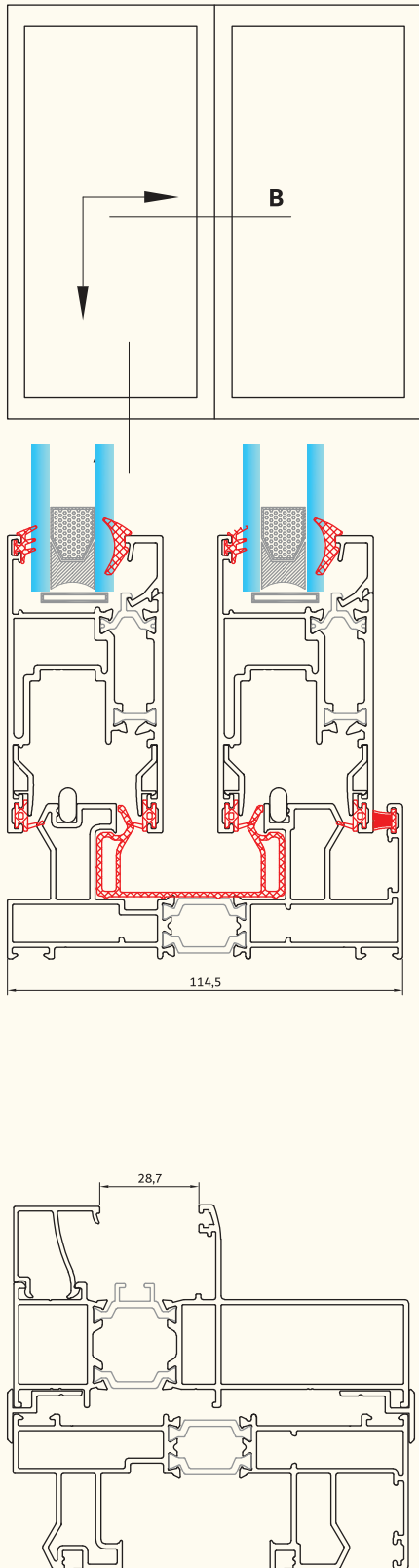

کشویی ترمال

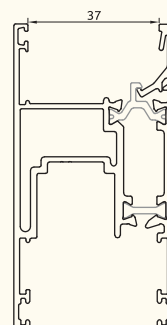
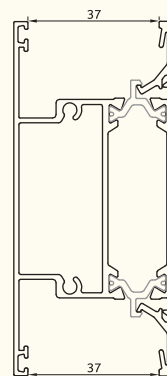
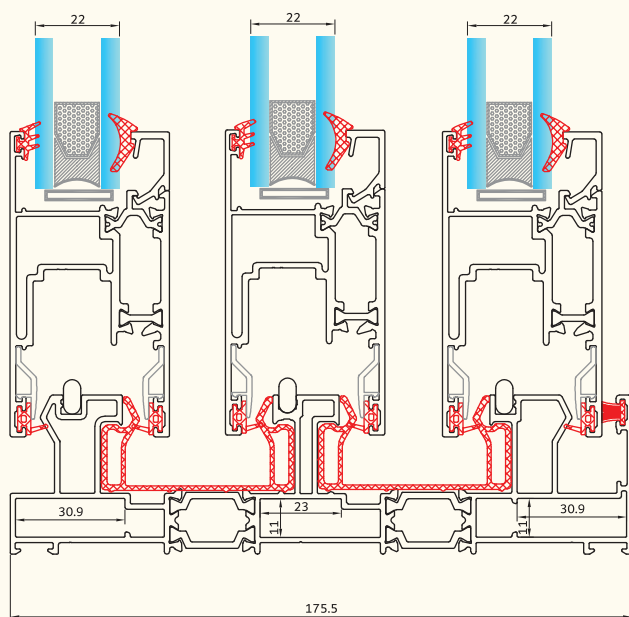
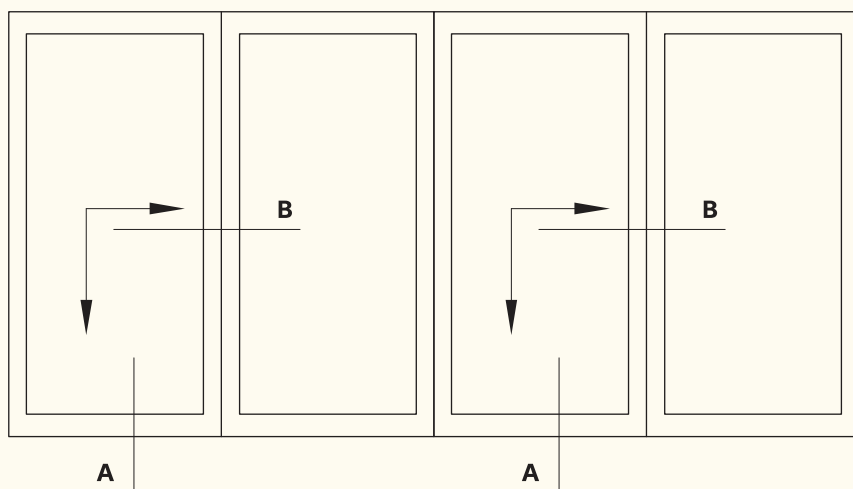

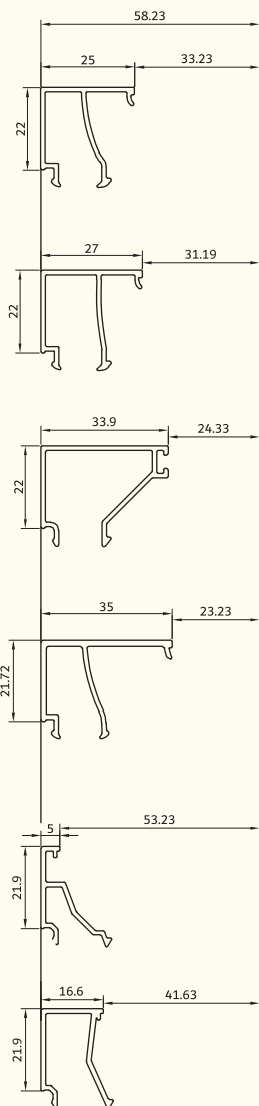

es-6100/tr

KA-4102.tr

Ka-68150tr

es-15150/tr

KA-1150

KA-1101

KA-10290

KA-1100

KA-1115

KA-1120

KA-4127.tr

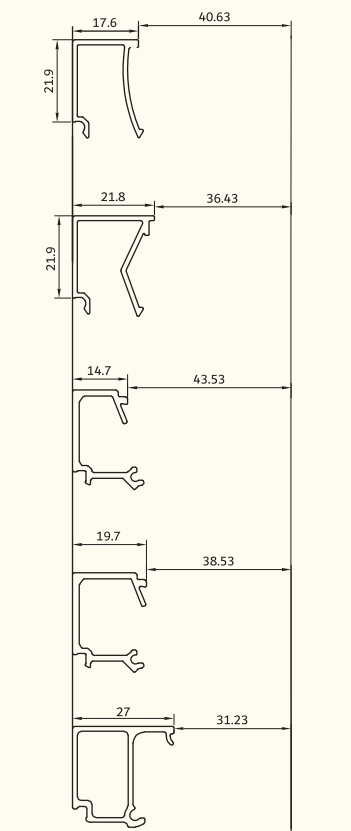



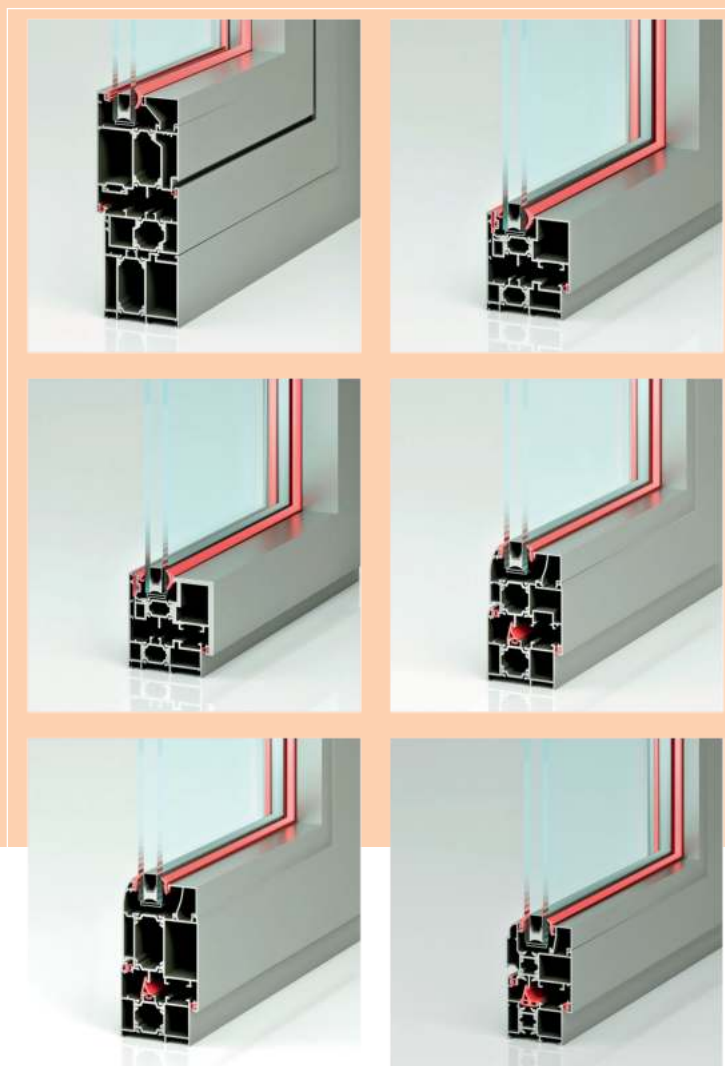

Thermal break
لولایی ترمال بریک



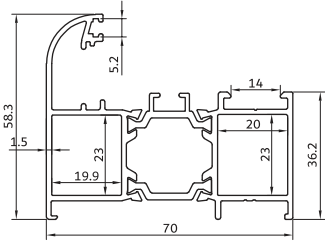

es-6251.tr

1430 gr/m

چهارچوب لولایی ۷۰

frame profiles

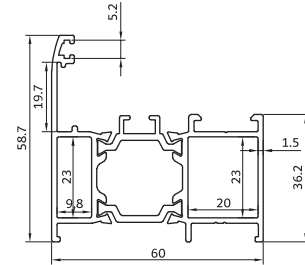

es-6250/tr

1300 gr/m

چهارچوب لولایی ۶۰

frame profiles

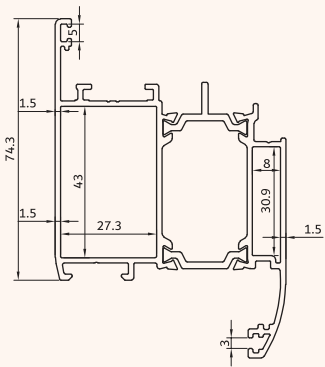

es-6201/tr

1900 gr/m

لنگه در لولایی

vent profiles

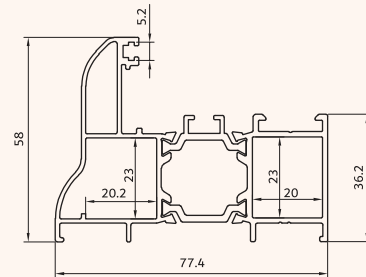

KA-1253.tr

1460 gr/m

چهارچوب لولایی ۷۰

frame profiles great

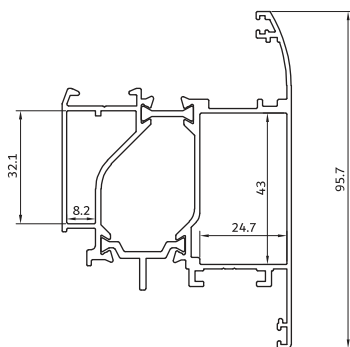

es-6301/tr

1800 gr/m

لنگه در لولایی بیرون بازشو

vent profiles

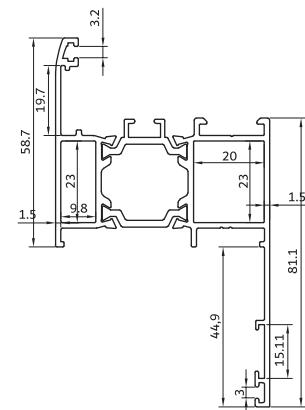

es-6254/tr

1530 gr/m

چهارچوب لولایی رکوب دار

frame profiles great

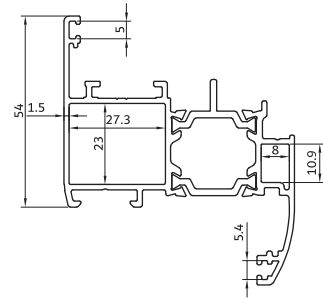

es-6200/tr

1450 gr/m

لنگه پنجره لولایی ۶۰

vent profils

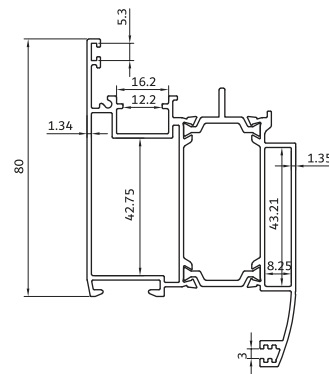

es-6201/s.tr

1900 gr/m

لنگه در لولایی اسپانیولت

vent profils

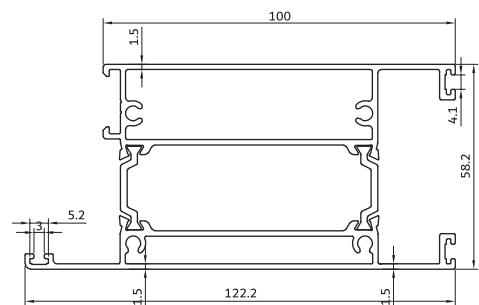

es-6260/tr

2350 gr/m

آستانه پایین در لولایی

low profile door

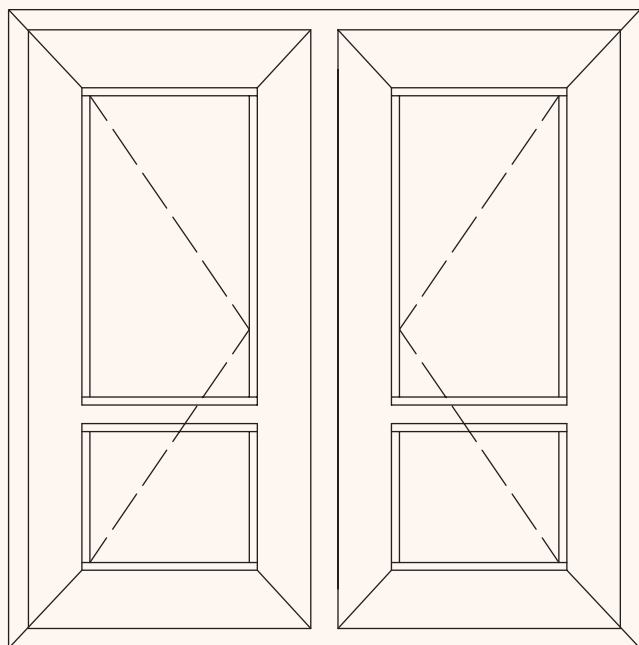

B

درب لولایی سری T 60

A

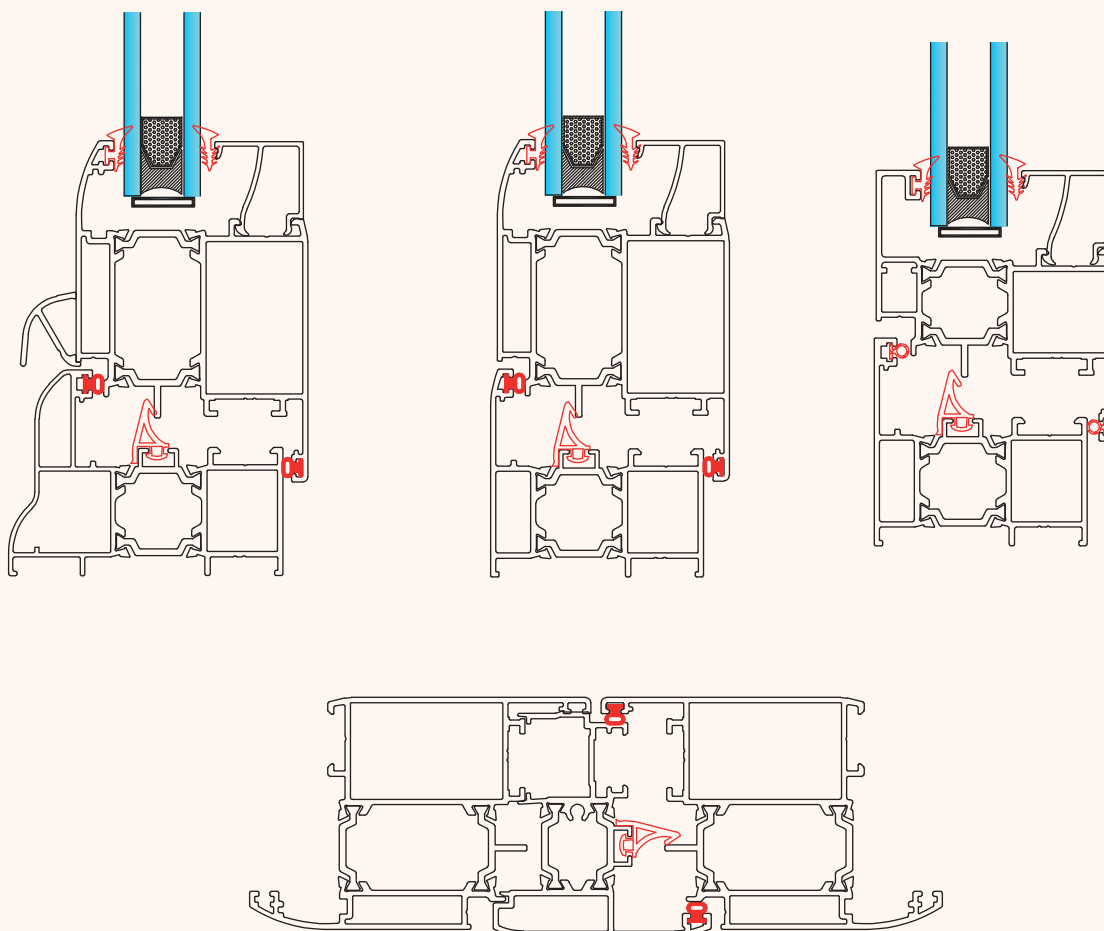

در ب لولایی سری T 60

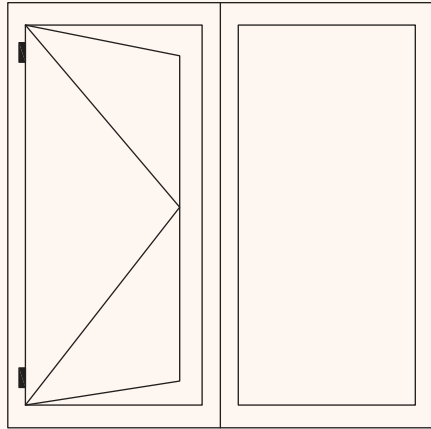

B

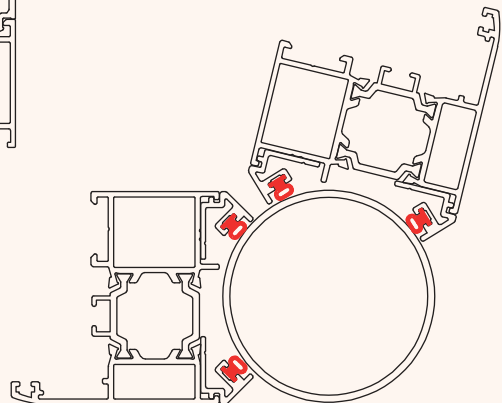
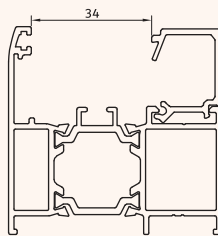
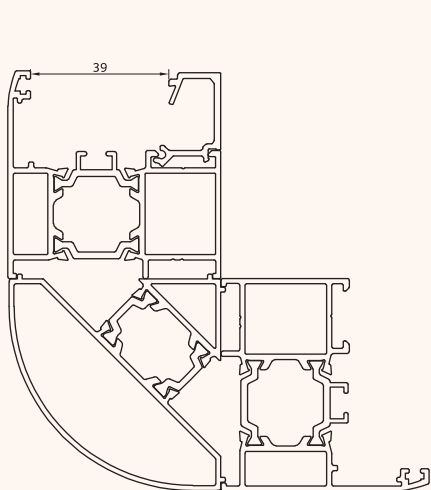
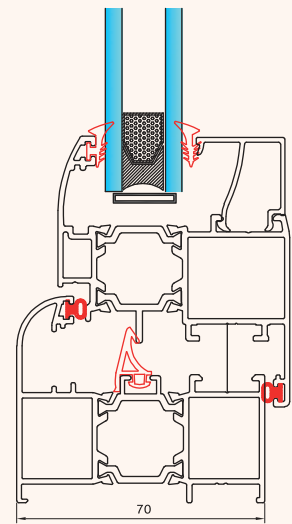
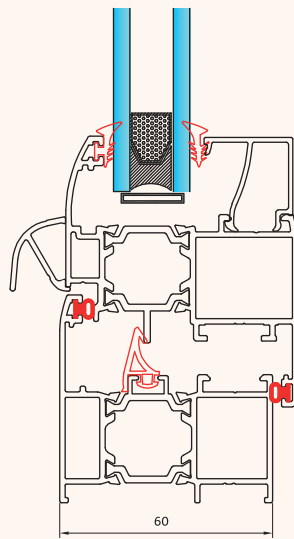
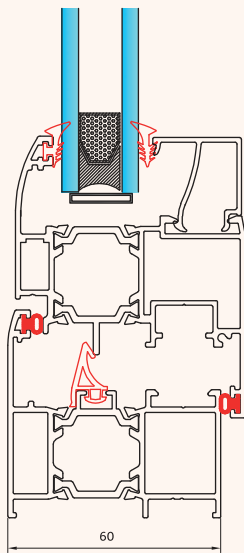

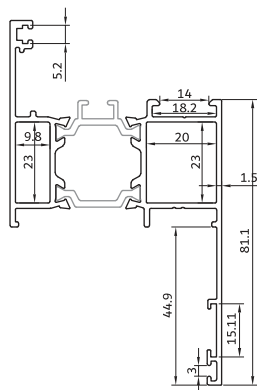
**es-6254/f.tr**

1530 gr/m

چهار چوب لولایی رکوب دار

frame profiles

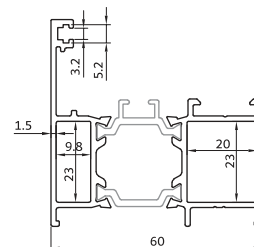
**es-6250/f.tr**

1300 gr/m

چهار چوب لولایی تخت

frame profiles

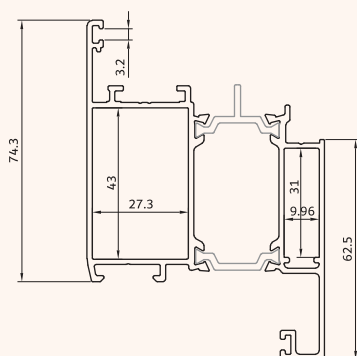
**es-6201/f.tr**

1900 gr/m

لنگه در لولایی تخت

vent profiles

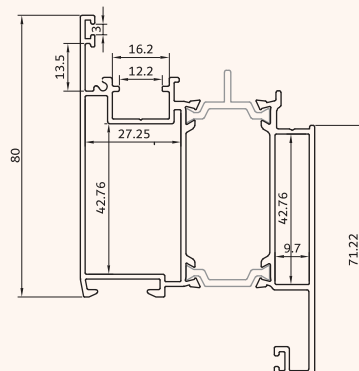
**es-6201/sf.tr**

1900 gr/m

لنگه در لولایی تخت اسپانیولت

vent profiles

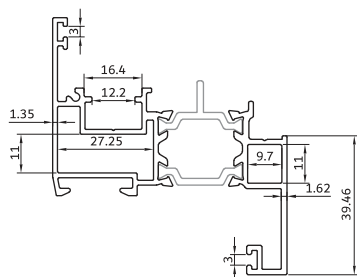
**es-6200/sf.tr**

1430 gr/m

لنگه پنجره اسپانیولت تخت

vent profiles

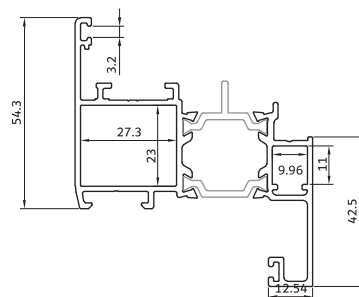
**es-6200/f.tr**

1500 gr/m

لنگه پنجره لولایی تخت

vent profiles

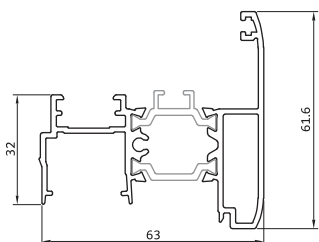

es-6249/tr دماغه متحرک دولنگه بازشو
1280 gr/m the middle vent profiles

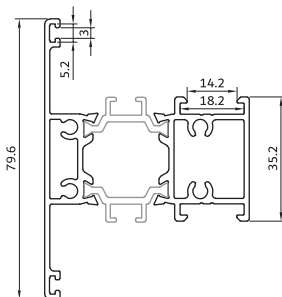

es-6400/tr سپری لولایی ۶۰
1560 gr/m tripetalous profiles

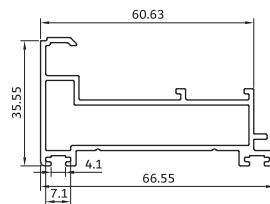

es-6260/sf پروفیل آستانه پایین در
870 gr/m low profiles door

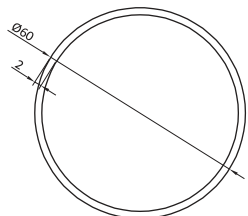

**ka-60**

980 gr/m

لوله محور کنج

axial tube

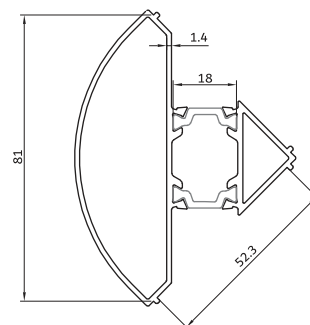
**es-520/tr**

1100 gr/m

کنج محور ۹۰ درجه

thermal tube axial

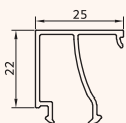
**es-6100/tr**

290 gr/m

زهوار دوجداره تخت

glass holder

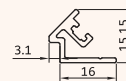
**es-519**

180 gr/m

آداپتور لوله کنج

rotating frame

**ka-510**

220 gr/m

آبچکان لنگه

water dropper profiles

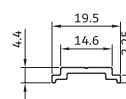
**es-515**

100 gr/m

تسمه رابط

strap profiles

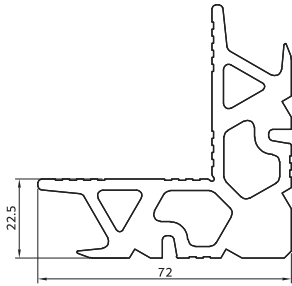

es-502

3700 gr/m

گونیا ۲۲

fixer

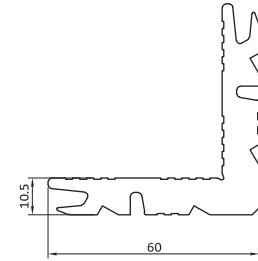

es-501

2550 gr/m

گونیا ۱۰

fixer

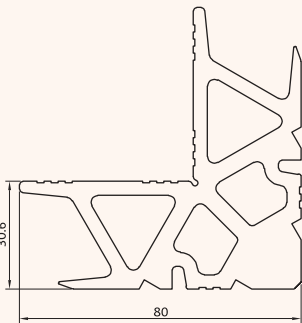

es-503

4750 gr/m

گونیا ۳۰

fixer

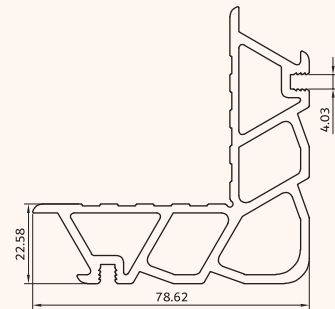

es-502/1

2700 gr/m

گونیا ۲۲ سبک

fixer

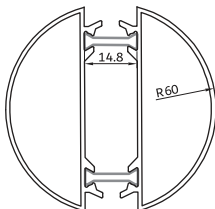

ka-68520 tr

1126 gr/m

لوله کنج محوری

fixer

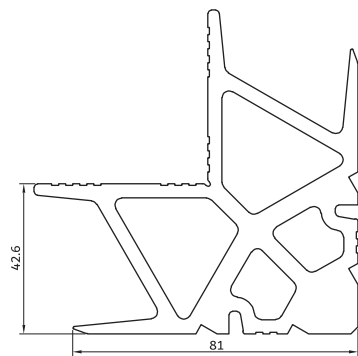

es-504

5650 gr/m

گونیا ۴۲

fixer

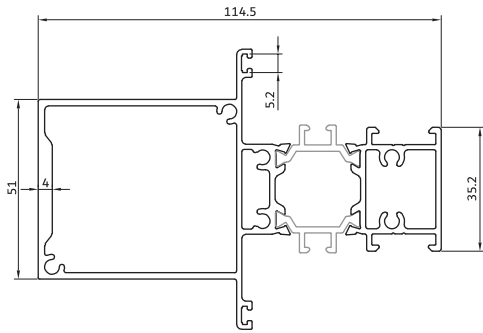

es-6455/tr

2975 gr/m

سپری تقویتی

strengthened tripetalous profiles

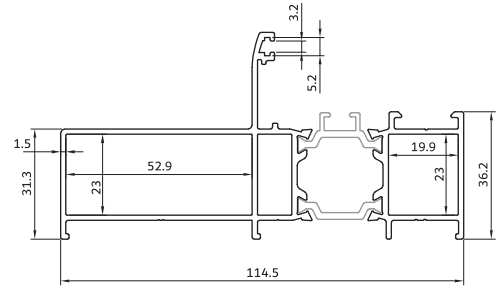

es-6255/tr

1865 gr/m

چهار چوب کتیبه

strengthened frame profiles

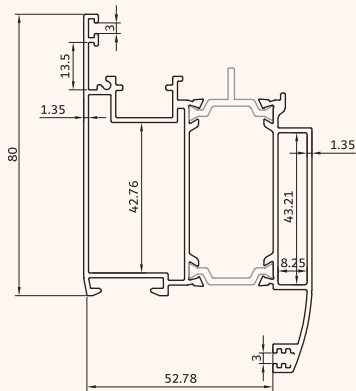

es-6201/s.tr

1900 gr/m

لنگه در لولایی اسپانیولت

vent profiles

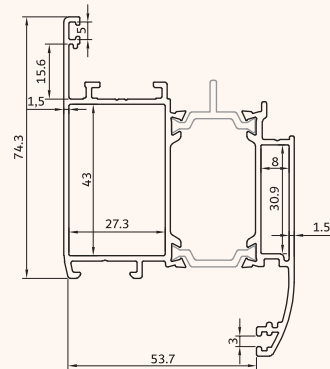

es-6201/tr

1900 gr/m

لنگه در لولایی

vent profiles

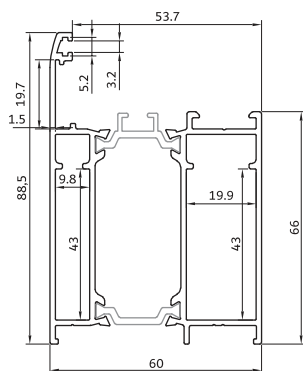

es-6256/tr

1800 gr/m

چهار چوب فولکس واگنی

frame profiles

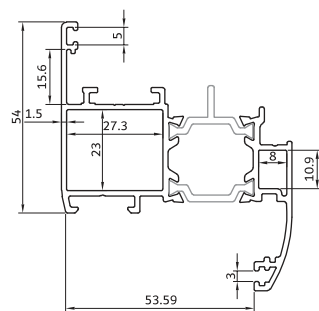

es-6200/tr

1450 gr/m

لنگه پنجره لولایی ۶۰

vent profiles

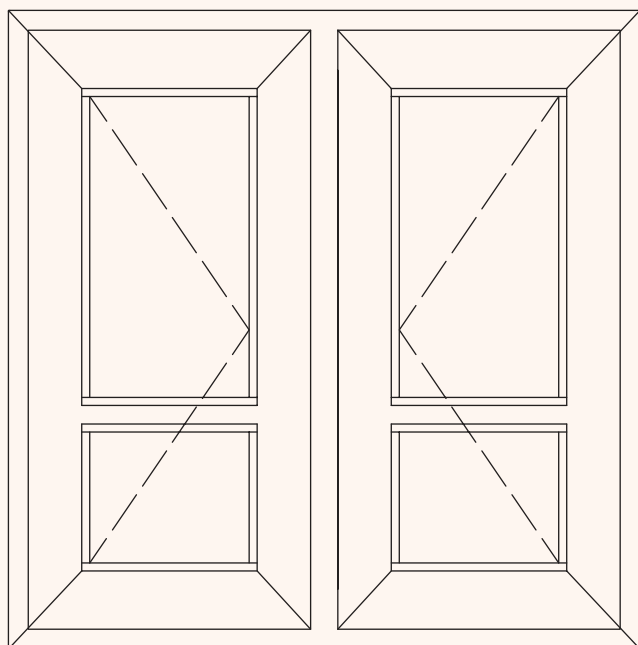

A

در و پنجره سری T 60 تقویت شده

B

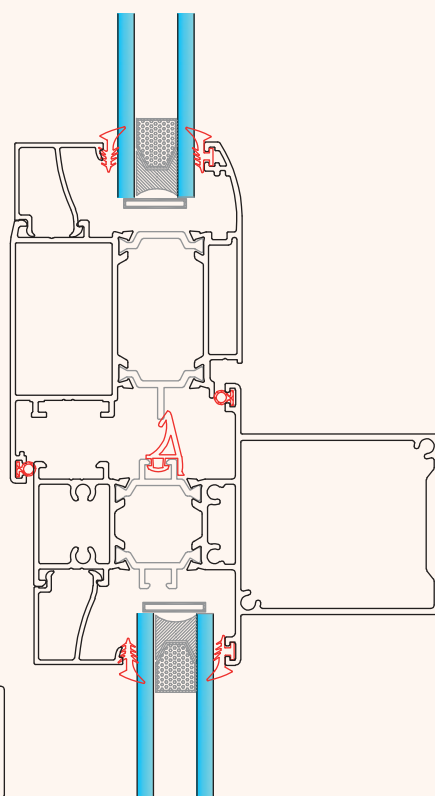
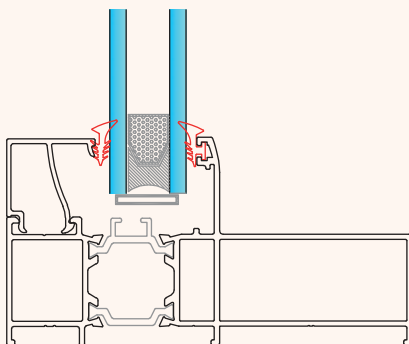
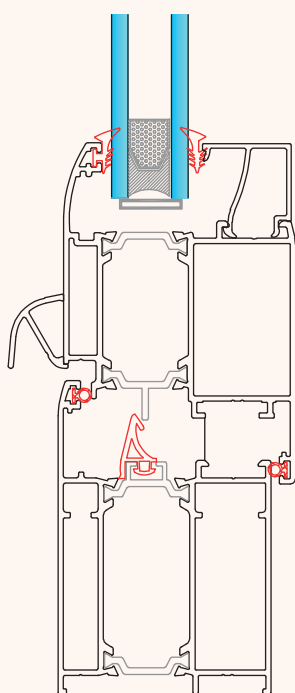
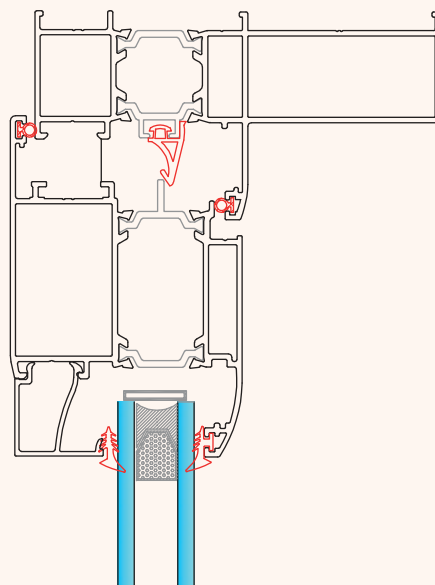

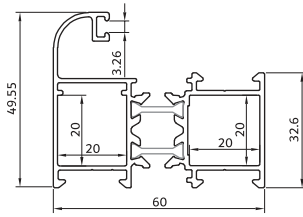

ka-1251.1/tr چهار چوب لولایی ۶۰
1190 gr/m frame profiles

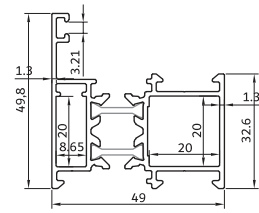

ka-1250.tr چهار چوب لولایی ۵۰
1050 gr/m frame profiles

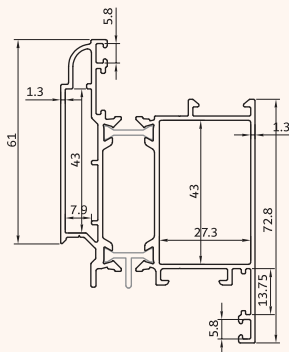

ka-1201.tr لنگه در لولایی
1670 gr/m vent profiles

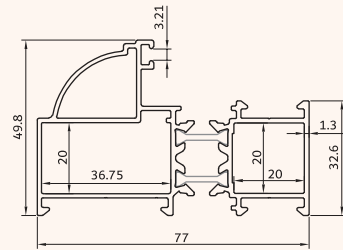

ka-1251.tr چهارچوب لولایی ۷۲
1370 gr/m frame profiles

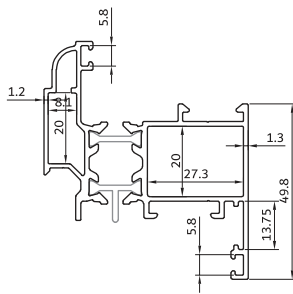

ka-1200.tr لنگه پنجره لولایی
1300 gr/m vent profiles

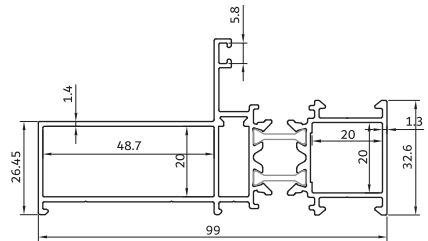

ka-1254.tr فریم کتیبه تقویتتی
1460 gr/m strengthened frame profiles

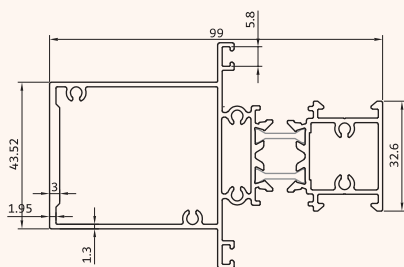

ka-1401.tr سپری تقویتتی
1960 gr/m strengthened tripetalous

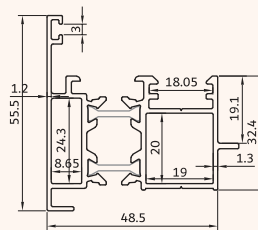

ka-1249.tr دماغه متحرک دونگه بازشو
1170 gr/m the middle vent

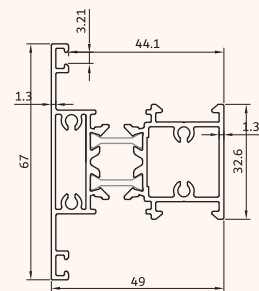

ka-1400.tr سپری لولایی
1265 gr/m tripetalous profiles

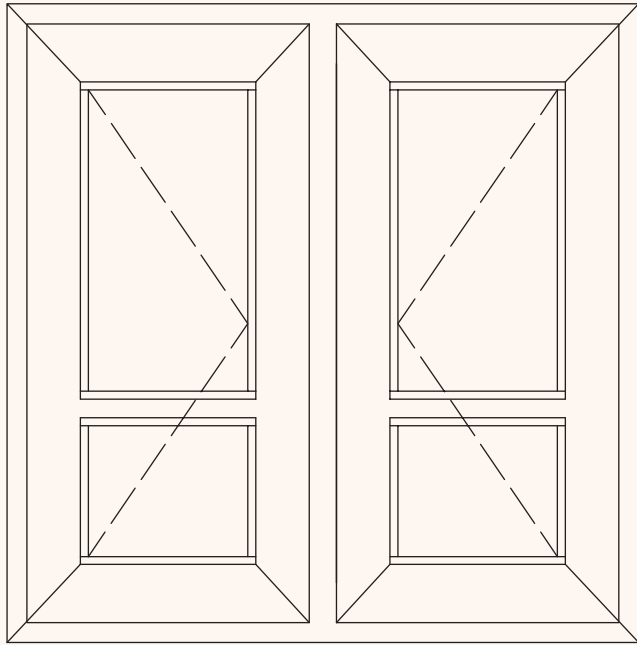

A

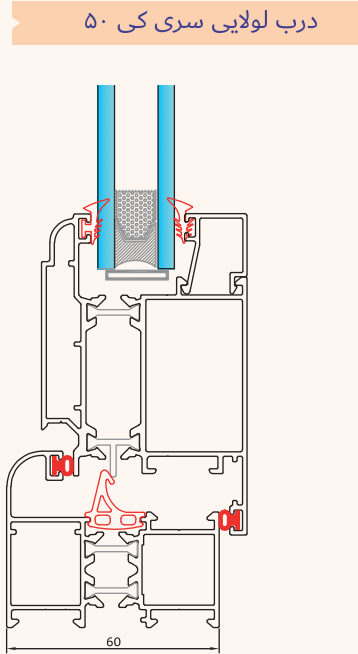

B

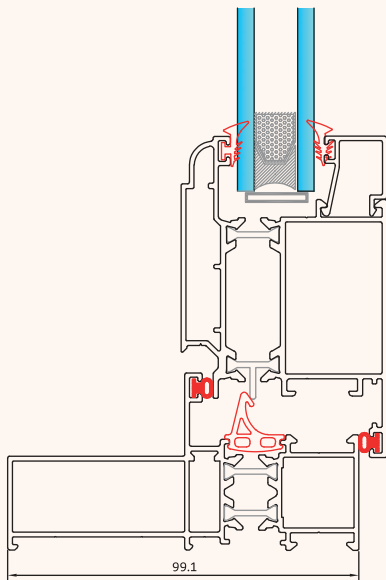

99.1

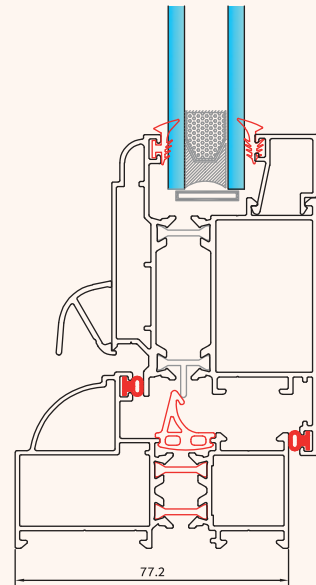

77.2

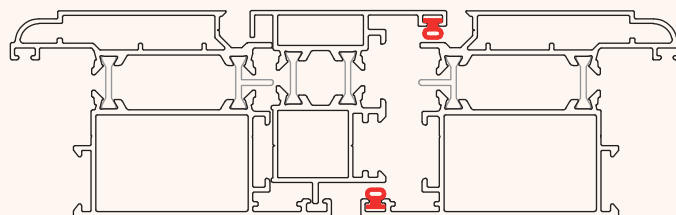

درب لولایی سری کی ۵۰

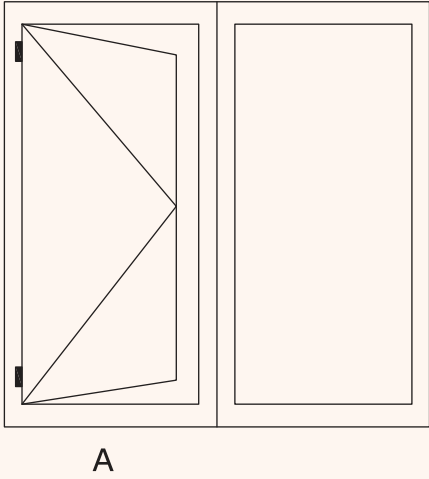

B

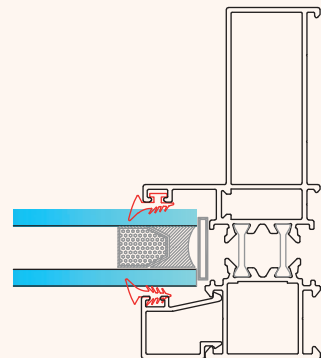
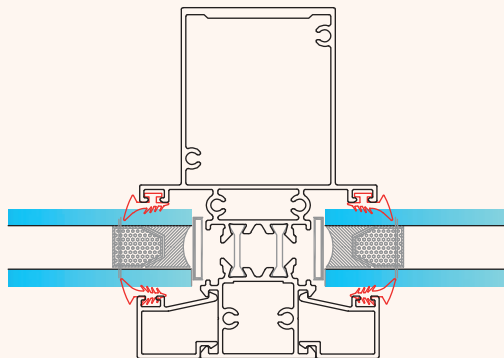
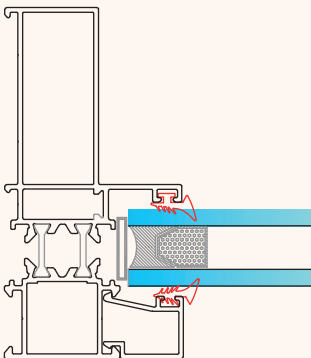
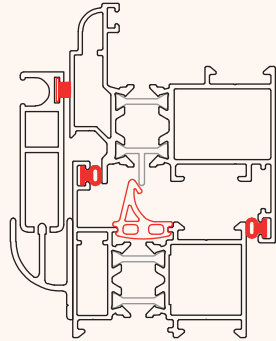
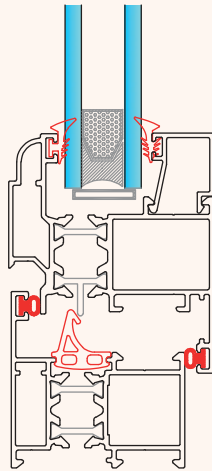
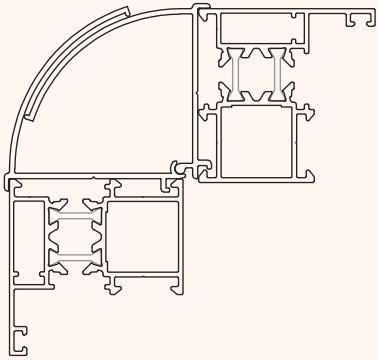
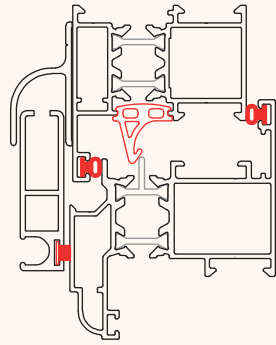

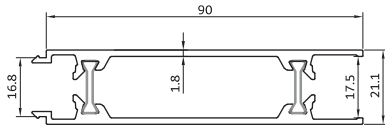

ka-521/tr ورق فاساد ترمال بریک
1272 gr/m thermal break facade

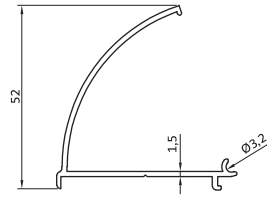

ka-S520/B پروفیل کنج
495 gr/m rotating frame

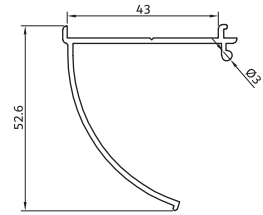

ka-S520/a پروفیل کنج
500 gr/m rotating frame

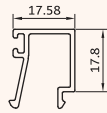

ka-1150.tr زهوار دوجداره تخت
245 gr/m glass holder

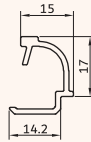

ka-5150 زهوار دوجداره گرد
220 gr/m glass holder

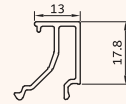

ka-5101 زهوار دوجداره تخت
220 gr/m glass holder

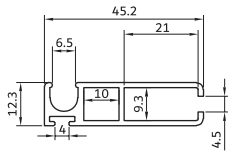

ka-5539 فریم توری
500 gr/m grid vent

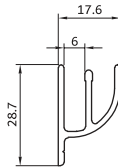

k-546 ریل توری لولایی پایین
330 gr/m grid rails down

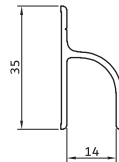

ka-545 ریل توری لولایی بالا
290 gr/m grid rails up

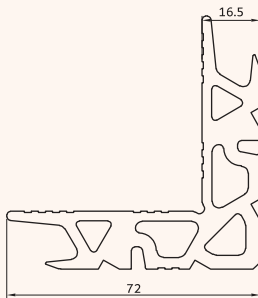

ka-499 گونیا ۱۶
1940 gr/m fixer

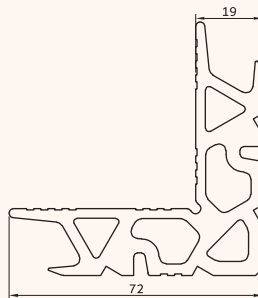

ka-505 گونیا ۱۹
3000 gr/m fixer

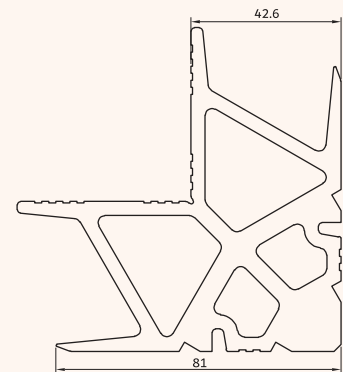

es-504 گونیا ۴۲
5650 gr/m fixer

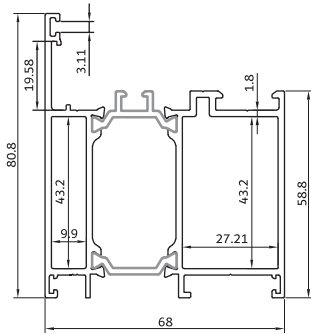

ka-68251 tr چهارچوب لولایی بزرگ ۶۸
2075 gr/m frame profiles

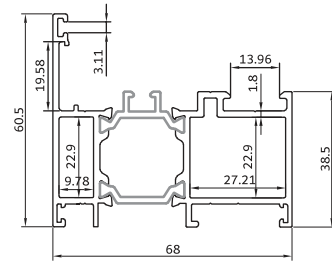

ka-68250 tr چهارچوب لولایی ۶۸
1666 gr/m frame profiles

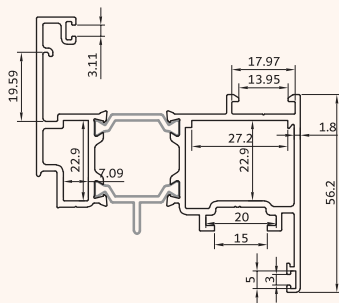

ka-68200 tr لنگه پنجره لولایی ۶۸
1906 gr/m vent profiles

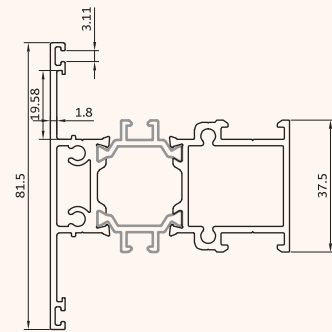

ka-68400 tr سپری لولایی ۶۸
1939 gr/m tripetalous profiles

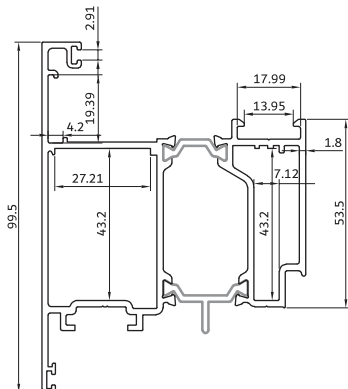

ka-68202 tr لنگه در بیرون باز شو ۶۸
2391 gr/m vent profiles

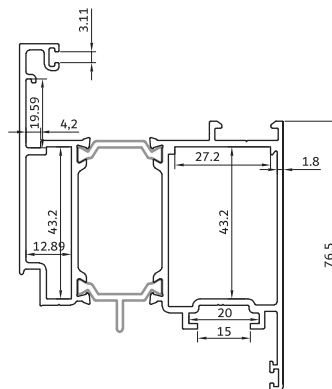

ka-68201 tr لنگه در لولایی ۶۸
2333 gr/m vent profiles

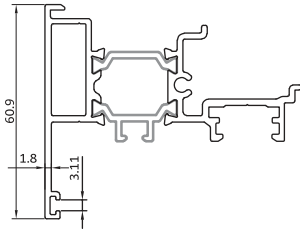

ka-68150 tr زهوار دو جداره تخت
352 gr/m glass holder

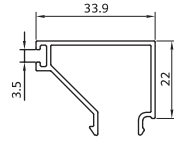

ka-68249 tr دماغه متحرک دو لنگه بازشو
1463 gr/m the middle vent

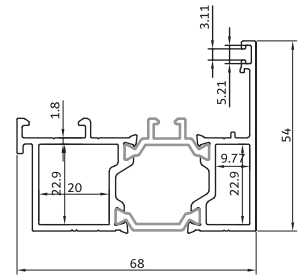

ka-68215 tr آداپتور بیرون بازشو
1666 gr/m outside opening adaptor



Habibi Industrial Group

Manufacturer of All Kinds of
DC Billet
Aluminum Sections
Powder Coating
Anodizing

در و پنجره ترمال بريك سري ۶۸

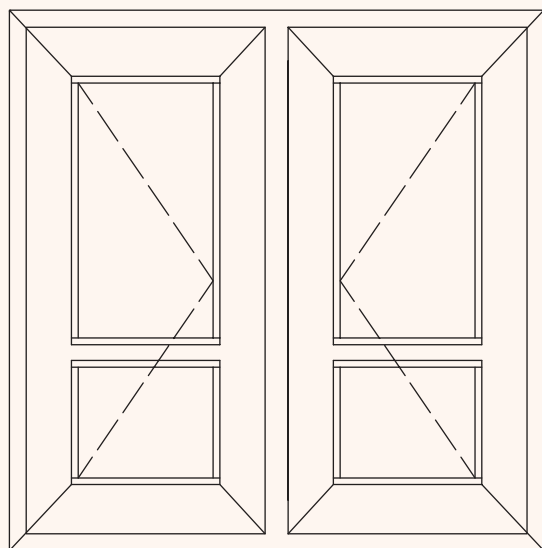

B

A

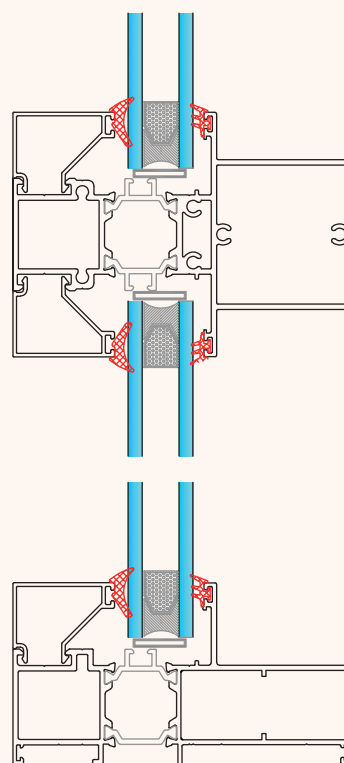
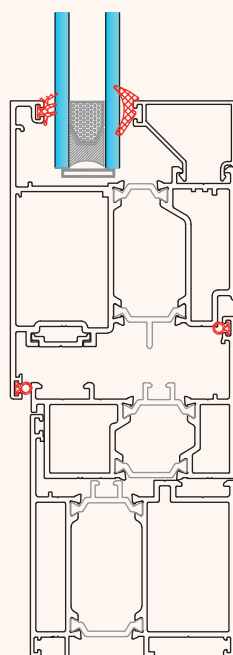
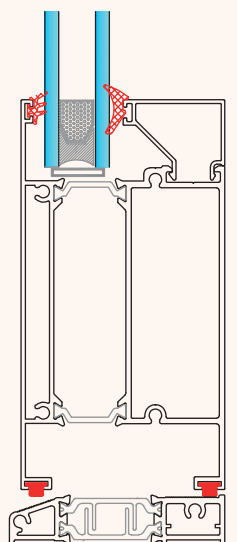
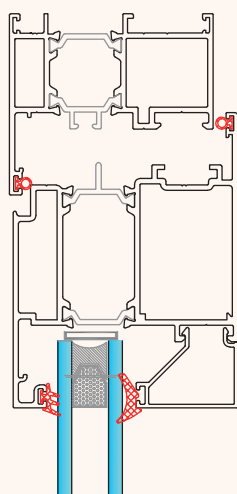

در و پنجره ترمال بریک سری ۶۸

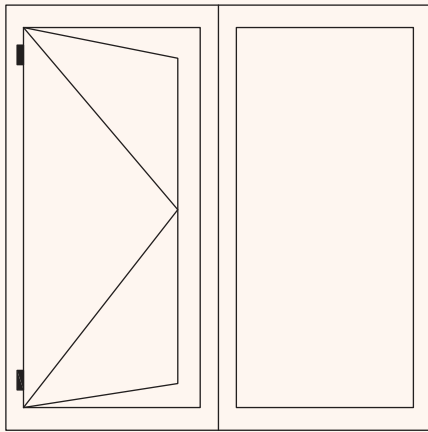

B

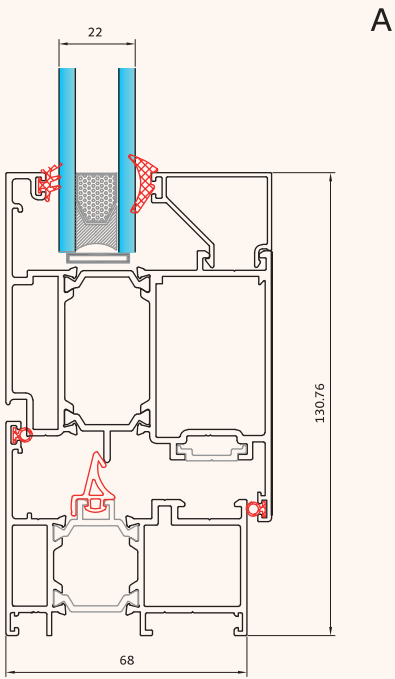

A

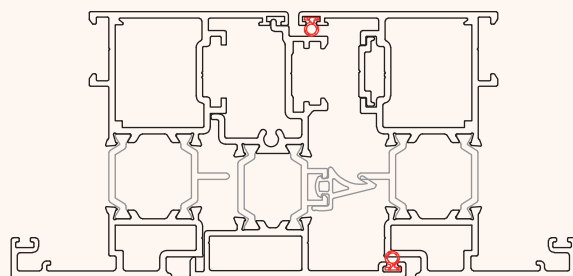
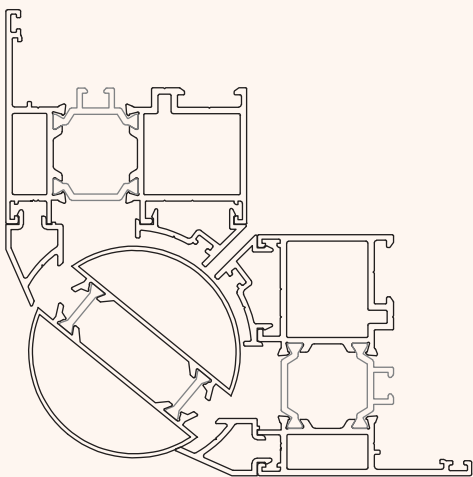
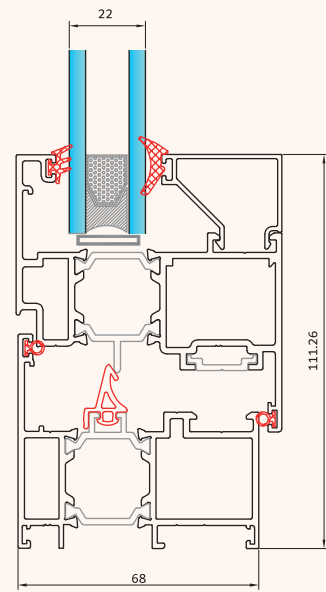

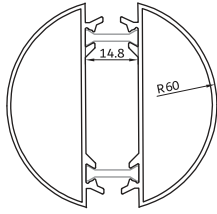
**ka-68520 tr**

1126 gr/m

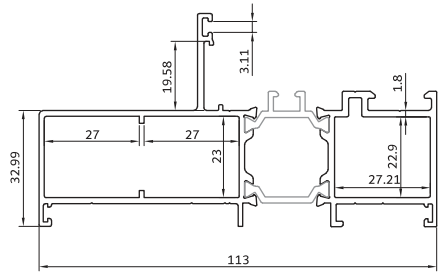
لوله کنج محوری
thermal tube axial**ka-68254 tr**

1970 gr/m

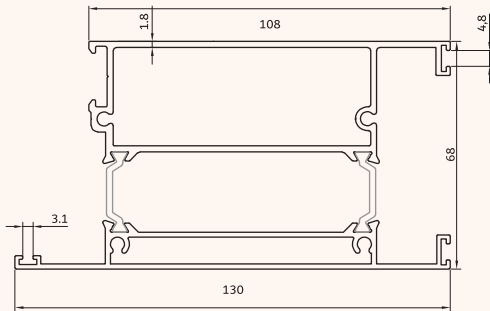
فرم کتیبه تقویتی
strengthened frame profiles**ka-68351 tr**

2314 gr/m

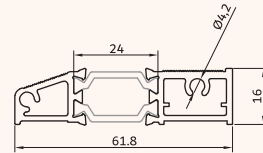
آستانه پایین در لولایی
low profile door**ka-68299 tr**

2391 gr/m

کف بند چهارچوب
door apron**es-515**

100 gr/m

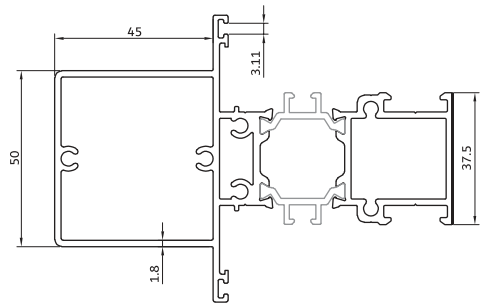
تسمه رابط
strap profiles**ka-68401 tr**

2725 gr/m

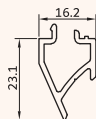
سپری کتیبه تقویتی
strengthened tripetalous**ka-68519 tb**

266 gr/m

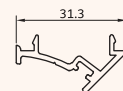
بیرون آداپتور لوله محور
rotating frame**ka-68519 ta**

249 gr/m

داخل آداپتور لوله محور
rotating frame

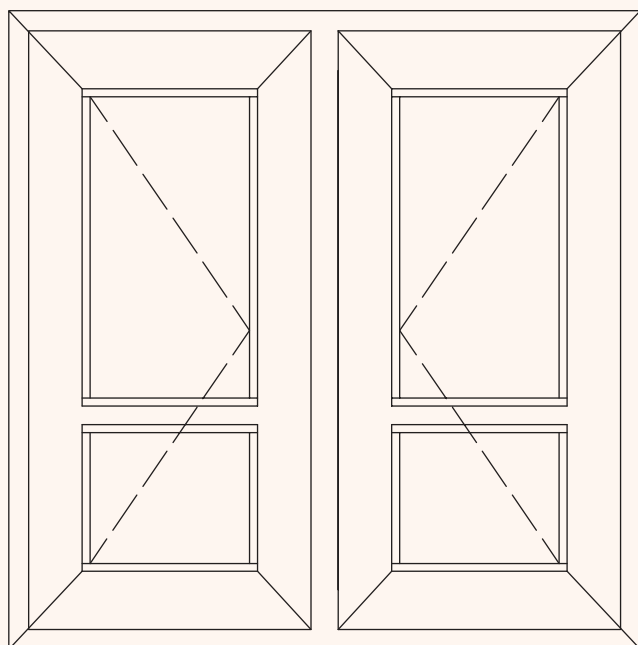

در و پنجره لنگه مخفی سری ۶۸

B

A

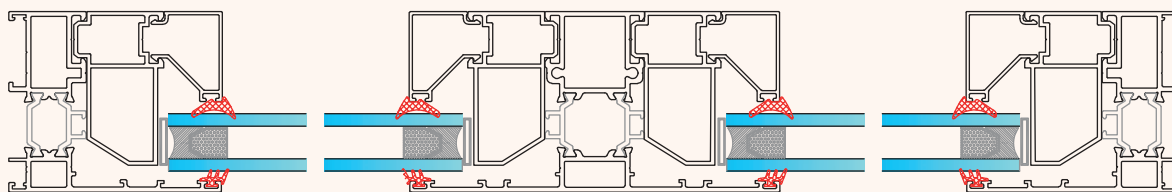
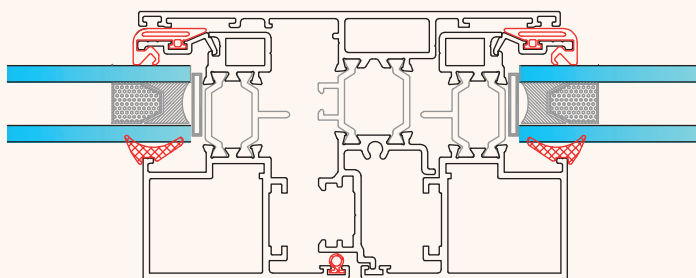
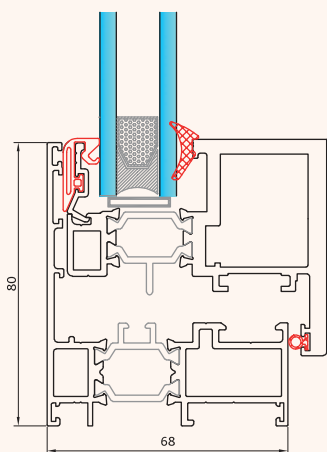

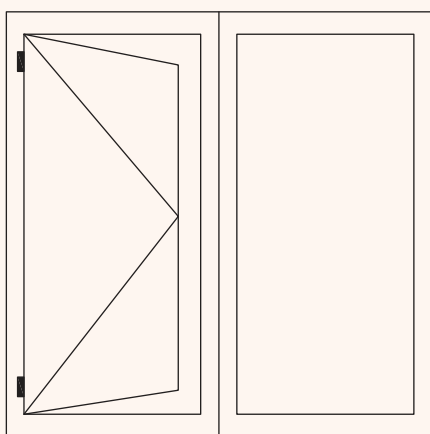

A

B

در و پنجره لنگه مخفی سری ۶۸

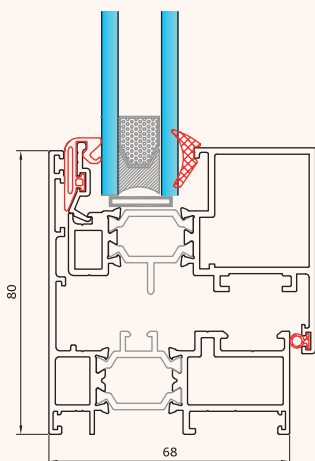
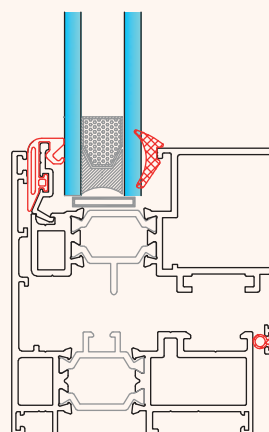
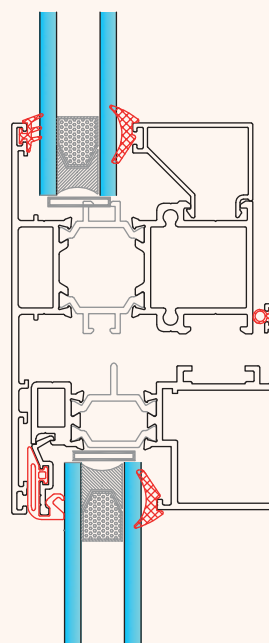
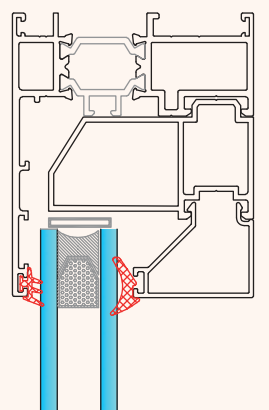

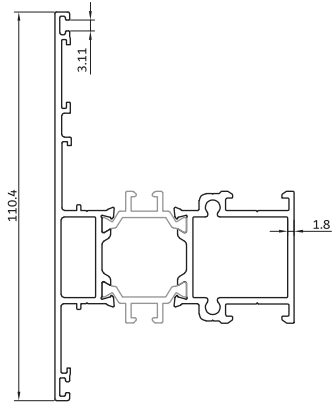

ka-68403 tr

2037 gr/m

سپری یک طرفه بازشو
tripetalous profiles

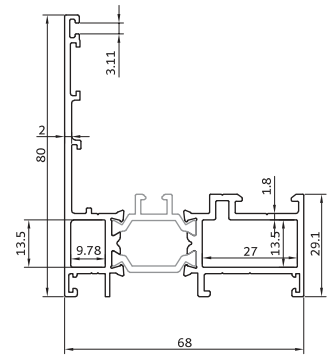

ka-68254 tr

1669 gr/m

چهارچوب لنگه مخفی ۶۸
frame profiles

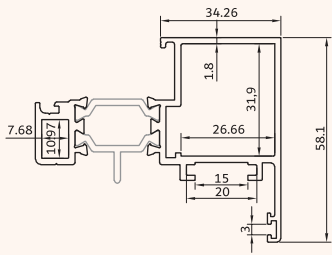

ka-68207 tr

1527 gr/m

لنگه درب مخفی ۶۸
vent profiles

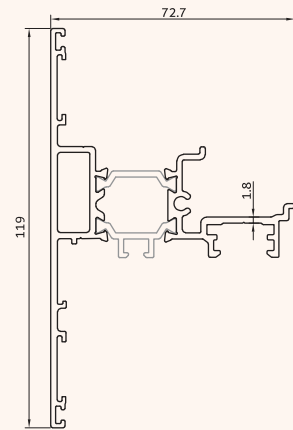

ka-68248 tr

1802 gr/m

دماغه متحرک دولنگه بازشو
the middle vent

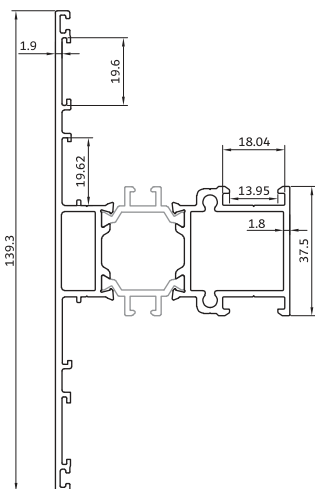

ka-68402 tr

2232 gr/m

سپری دو طرف فیکس
vent profiles

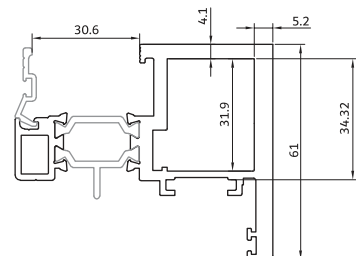

ka-68208 tr

2232 gr/m

لنگه درب مخفی ۶۸
vent profiles

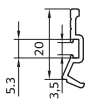

ka-68102 tr زهوار لنگه در و پنجره مخفی

152 gr/m

glass holder

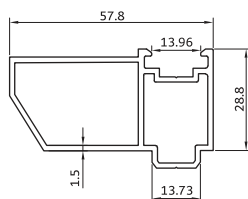

ka-68214 tr آداپتور قسمت فیکس

871 gr/m

adaptor profils

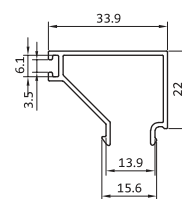

ka-68150 tr زهوار دوجداره تخت

352 gr/m

glass holder



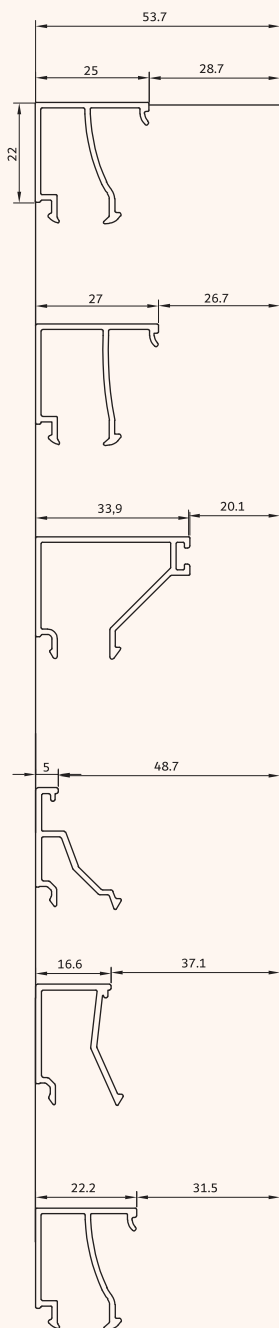

es - 6100 / tr

ka - 4102 . tr

ka - 68150 tr

ka - 1150

ka - 1101

es - 6122/tr

ka - 1100

ka - 1115

ka - 1120

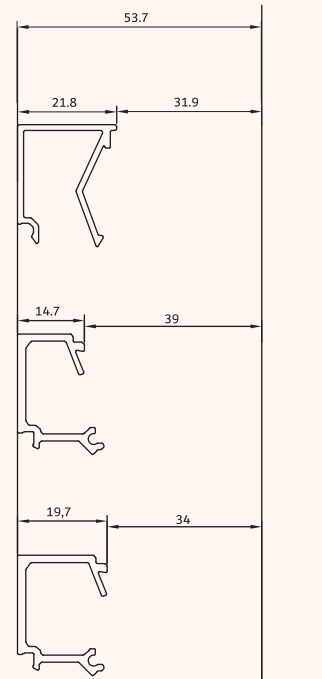

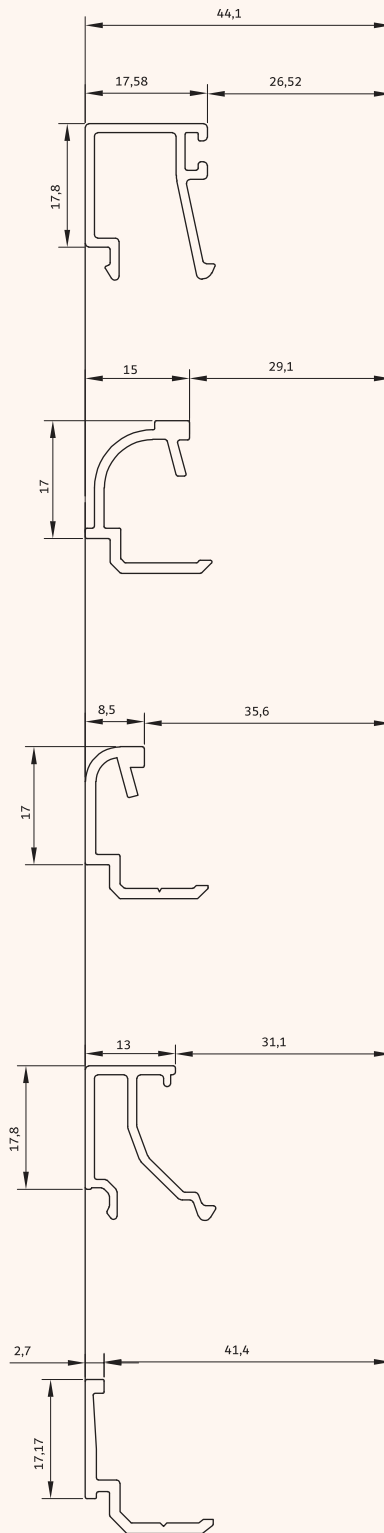

ka - 1150 . tr

ka - 5150

ka - 5050

ka - 5101

ka - 5051

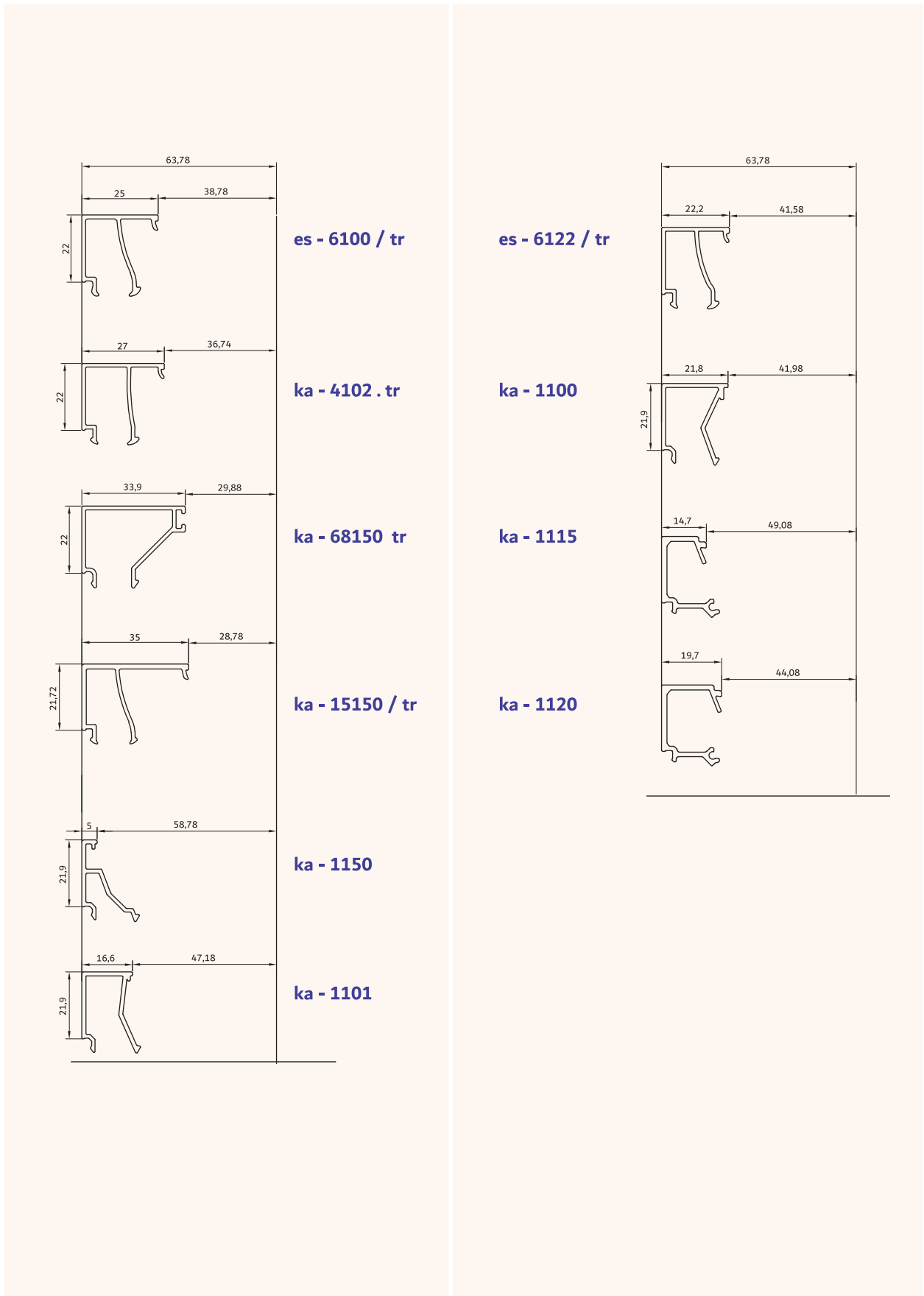



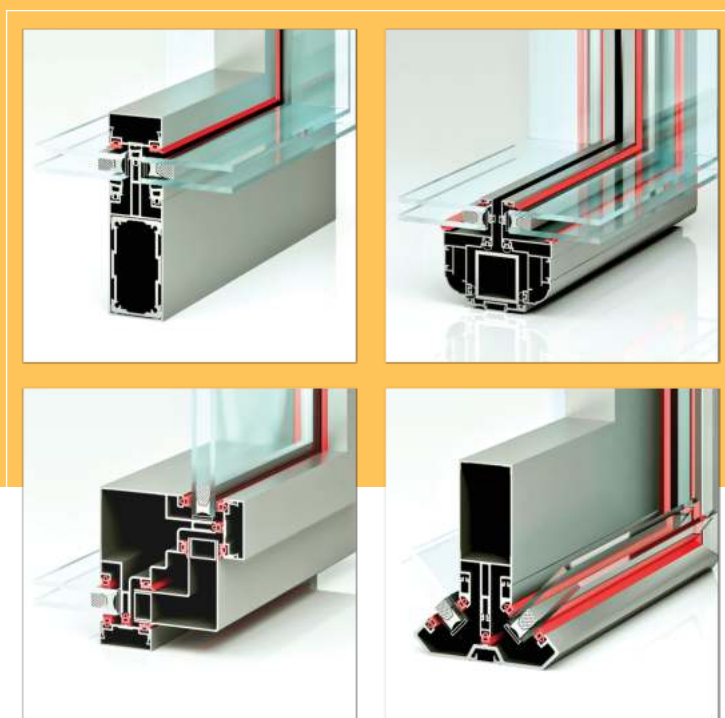

frameless
سیستم کرتین وال



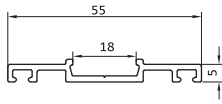

ka-527
320 gr/m

روکوب ۵.۵
gap for iron box

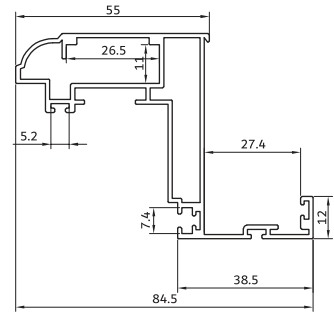

ka-1208
1100 gr/m

لنگه فریم لس
double glazed opening

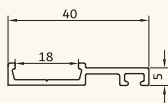

ka-525
230 gr/m

روکوب ۴
gap for iron box

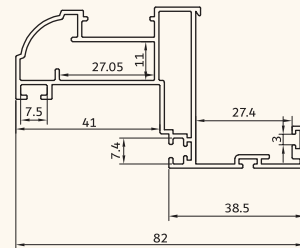

KA-1207
990 gr/m

فریم لس فیکس
fixed double glazing profiles

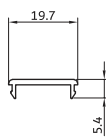

ka-517
100 gr/m

درپوش فریم لس و روکوب
screw cap

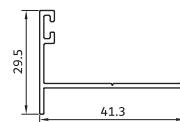

ka-508
260 gr/m

دماغه پشت لنگه
frame profiles great

فریم لس فیکس و بازشو

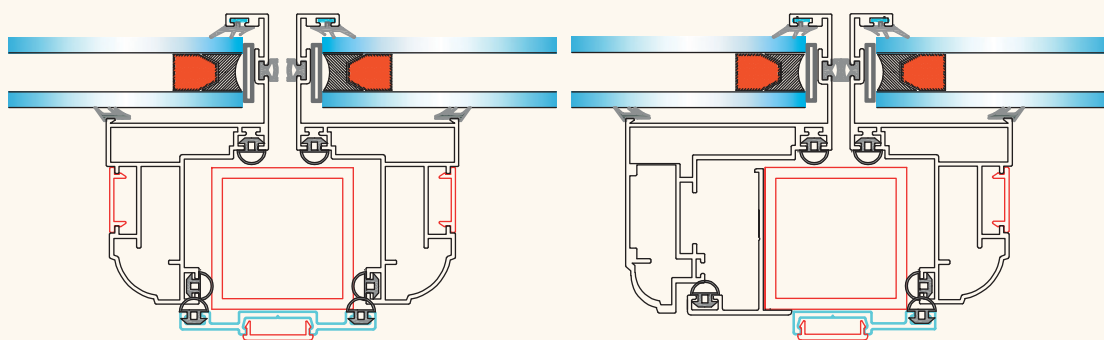
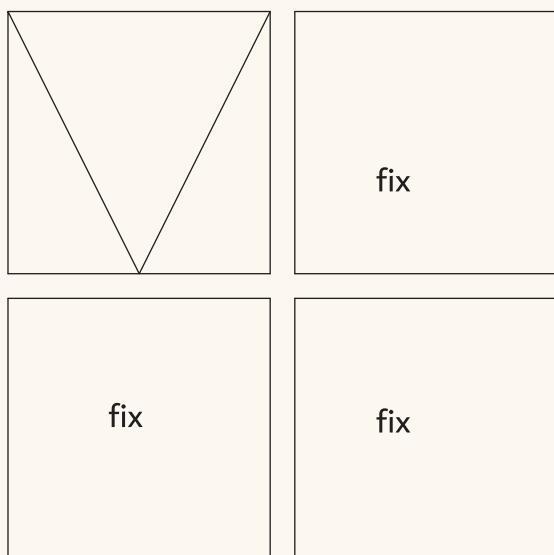

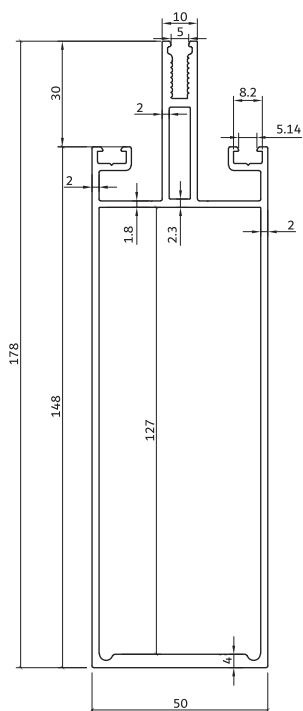

ka-10419
3196 gr/m

لامل عمودی ۱۵
vertical profiles

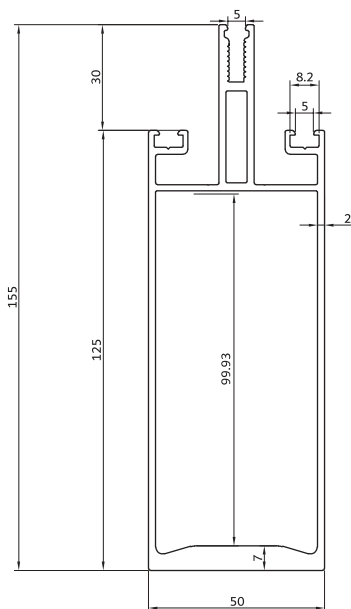

ka-5003
3179 gr/m

لامل عمودی ۱۳
vertical profiles

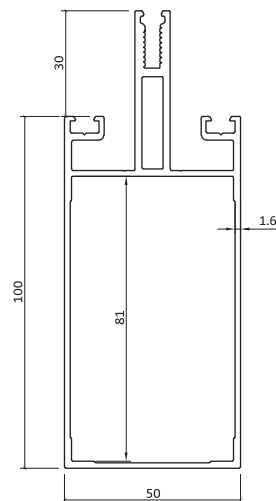

ka-5004
2140 gr/m

لامل عمودی ۱۰
vertical profiles

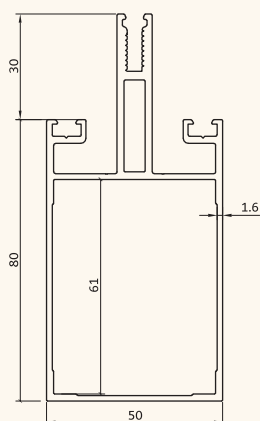

ka-5006
1960 gr/m

لامل عمودی ۸
vertical profiles

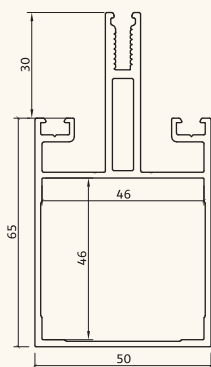

ka-21259
1775 gr/m

لامل عمودی ۶.۵
vertical profiles

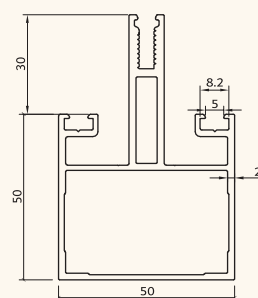

ka-20749
1700 gr/m

لامل عمودی ۵
vertical profiles

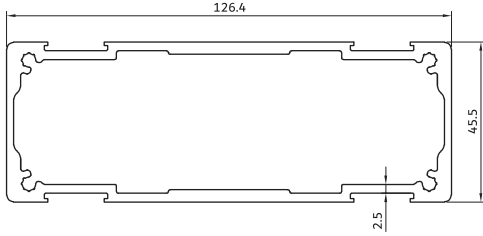

ka-5015

2900 gr/m

لقمه عمودی لامل ۱۵

vertical pice

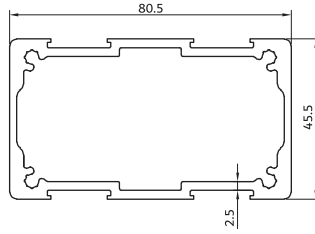

ka-5018

2100 gr/m

لقمه عمودی لامل ۱۰

vertical pice

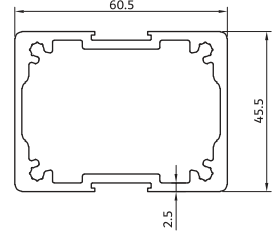

ka-5019

1800 gr/m

لقمه عمودی لامل ۸

vertical pice

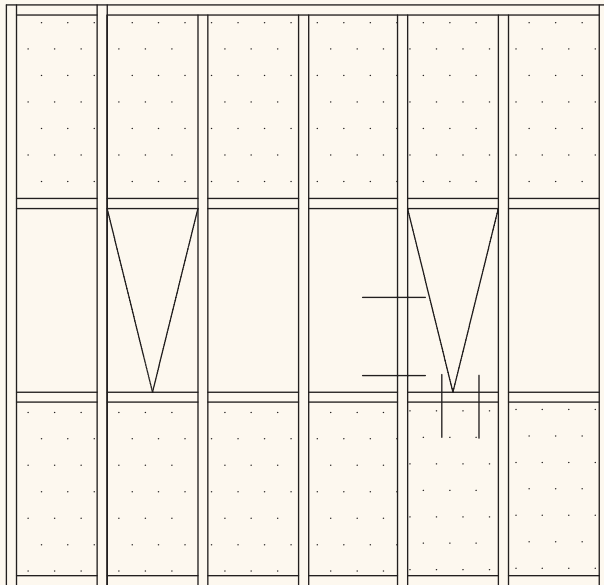

سیستم کرتین وال

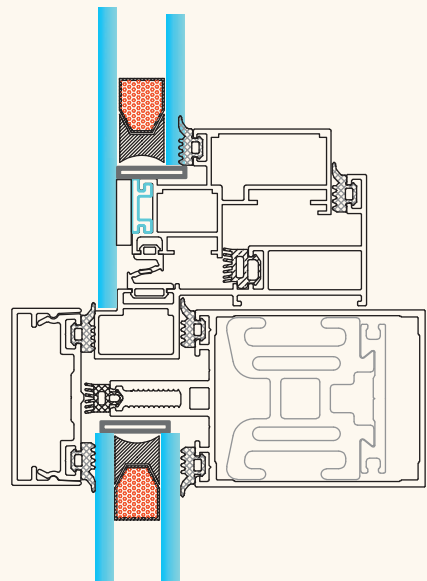
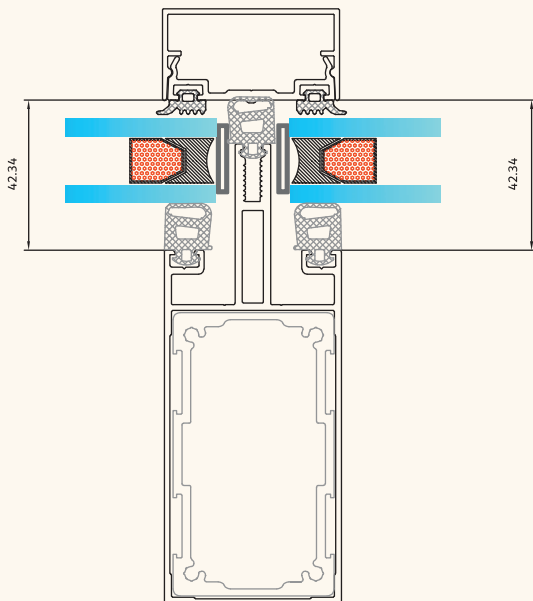

Curtain wall system

افقی سیستم کرتین وال

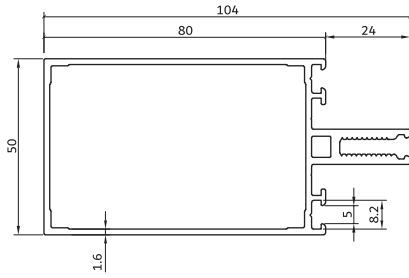

ka-5010

1650 gr/m

لامل افقی ۸

horizontal profiles

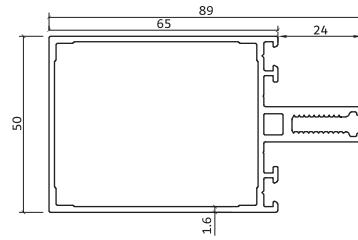

ka-5011

1500 gr/m

لامل افقی ۶.۵

horizontal profiles

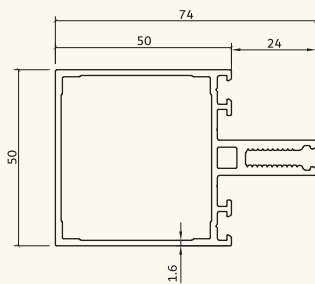

ka-20748

1350 gr/m

لامل افقی ۵

horizontal profiles

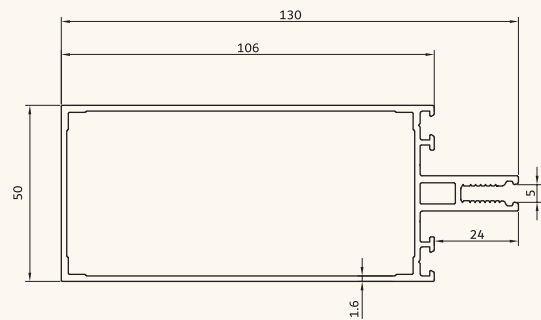

ka-20855

1870 gr/m

لامل افقی ۱۰.۵

horizontal profiles

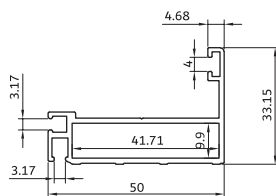

ka-10241

660 gr/m

فریم باز شو لامل

opening frame

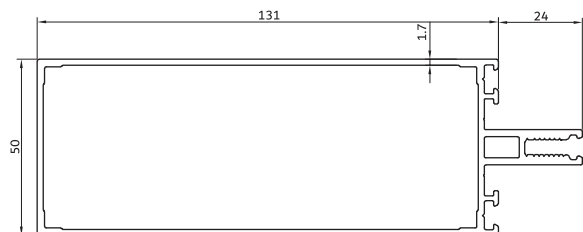

ka-20998

2196 gr/m

لامل افقی ۱۳

horizontal profiles



ka-21036

77 gr/m

اتصال شیشه لنگه

opening sash

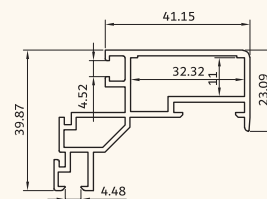

ka-21035

935 gr/m

لنگه باز شو لامل

opening sash

ka-5014
2900 gr/m

لامل کنج ۹۰ درجه بیرونی
90° internal profiles

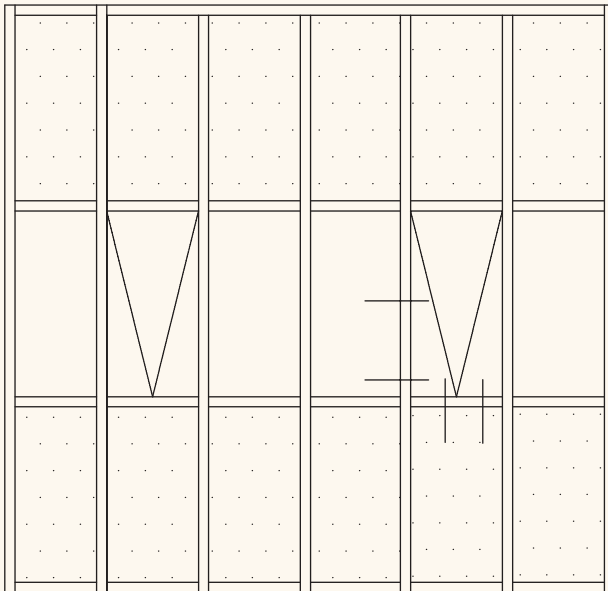
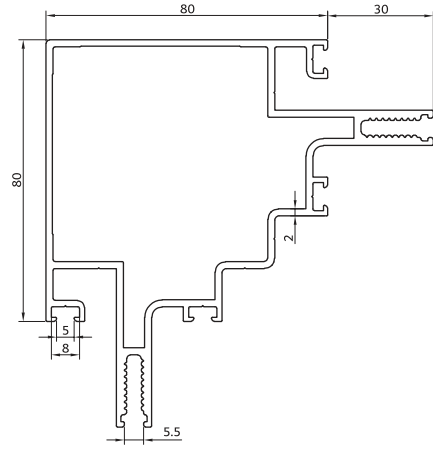

سیستم کرتین وال

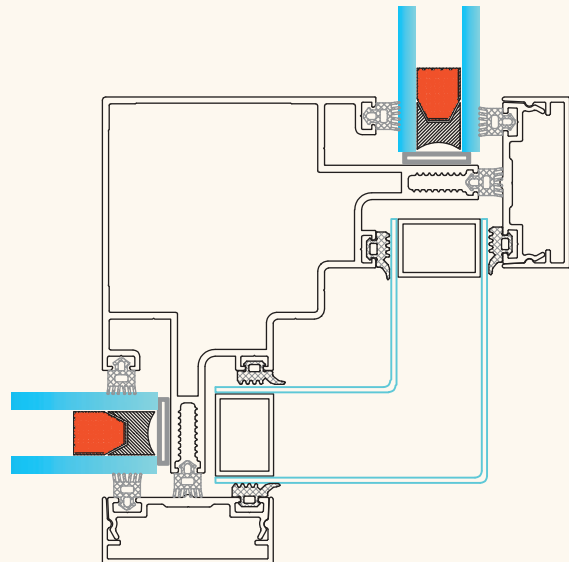
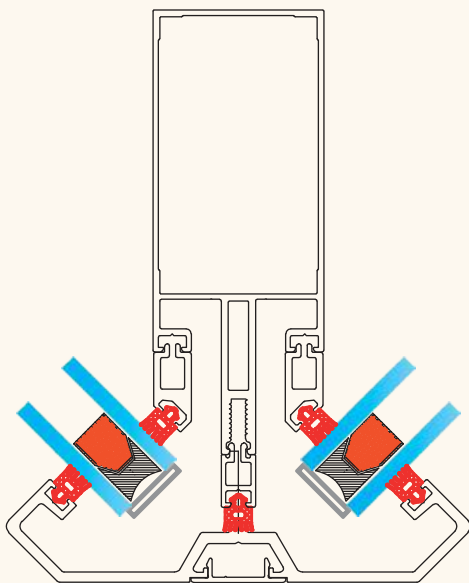

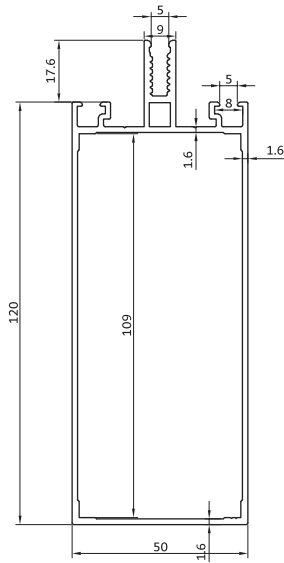
**ka-20892**

1971 gr/m

لامل عمودی ۱۲

vertical profiles

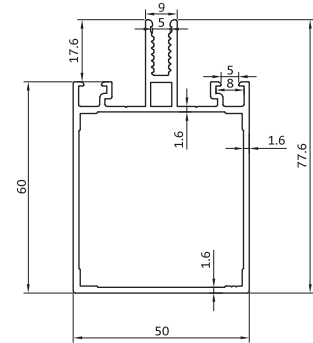
**ka-20879**

1419 gr/m

لامل افقی ۶

horizontal profiles

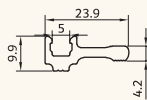
**ka-20888**

270 gr/m

لقمه اسپیسر یک طرفه

connection pieces

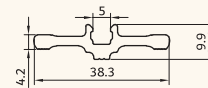
**ka-20889**

410 gr/m

لقمه اسپیسر دو طرفه

connection pieces

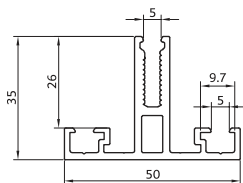
**ka-21241**

850 gr/m

لامل ادان

connection pieces

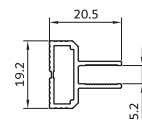
**ka-20887**

252 gr/m

اسپیسر شیشه دو جداره

connection pieces

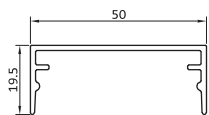

**ka-2006**

380 gr/m

درپوش ۱۹

horizontal cap

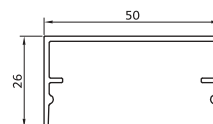
**ka-2009**

430 gr/m

درپوش ۲۶

vertical cap

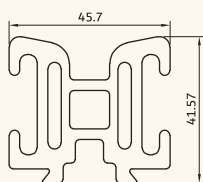
**ka-5041**

2180 gr/m

لقمه کشویی اتصال افقی

sliding piece

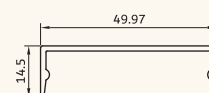
**sa-2**

313 gr/m

درپوش درپوش ۱۴

horizontal cap

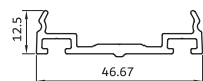
**ka-5048**

410 gr/m

نگهدارنده درپوش

cap irckty

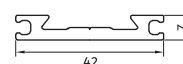
**ka-5040**

450 gr/m

پایه لقمه کشویی

sliding piece

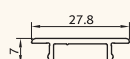
**ka-10809**

150 gr/m

درپوش پیچ ۹۰ درجه

screw cape

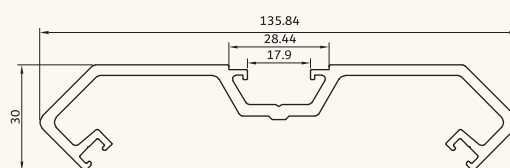
**ka-21236**

1900 gr/m

درپوش زاویه ۹۰ درجه

90° outer corner profiles

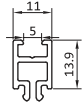

ka-21103

195 gr/m

آداپتور شیشه

single glass profiles

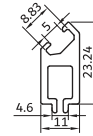

ka-20756

350 gr/m

آداپتور کنج ۹۰ درجه

90° outer corner adaptor

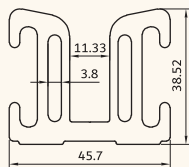

ka-20891

2070 gr/m

لقمه اتصال افقی فیکس

fix piece

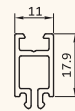

ka-20977

222 gr/m

آداپتور شیشه

single glass profiles

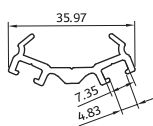

**ka-2526**

405 gr/m

نگهدارنده کپ ۱۳۵

135 cap irckty

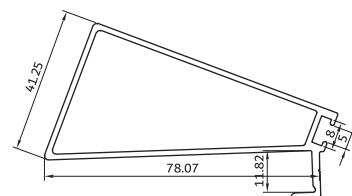
**ka-21273**

960 gr/m

آداپتور زاویه ۱۳۵ درجه

135° outter comer adaptor

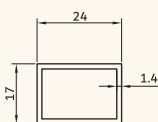
**ka-21142**

308 gr/m

قوطی قسمت فیکس لامل

opening sash

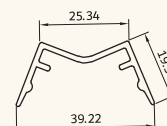
**ka-2525**

400 gr/m

کپ ۱۳۵

135 horizontal cap

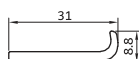
**ka-21015**

258 gr/m

فیلر زیر شیشه

glazing support

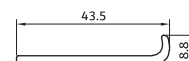
**ka-21101**

330 gr/m

فیلر زیر شیشه

glazing support

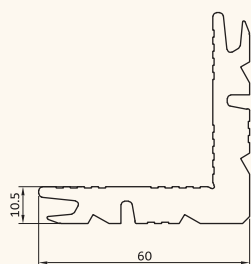
**es-501**

2550 gr/m

گونیا ۱۰

fixer

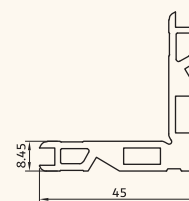
**ka-10338**

1190 gr/m

گونیا ۸.۵

fixer

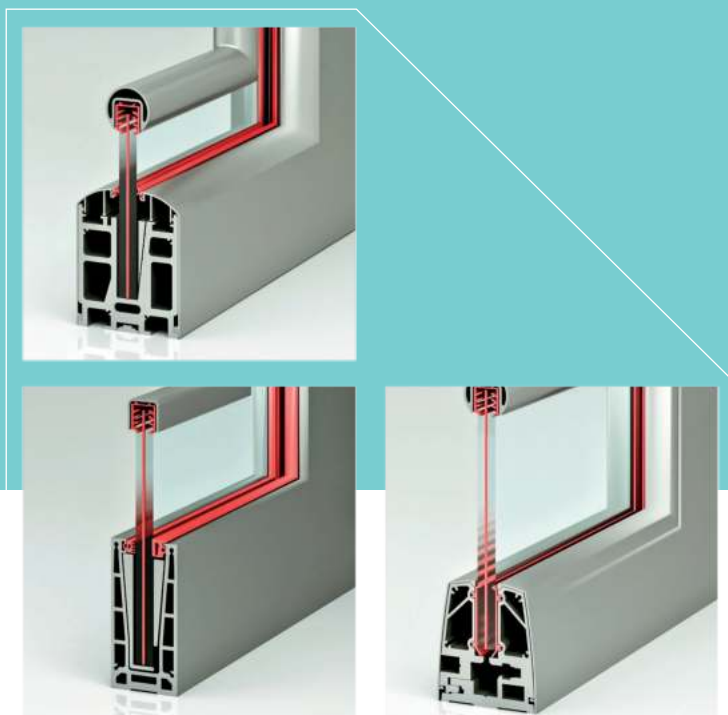

verandah fence system
هند ریل

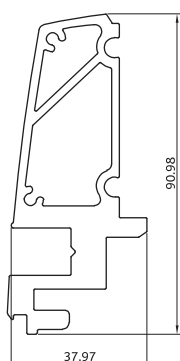

**HB-202**

2950 gr/m

پروفیل شیشه گیر
glass stuck

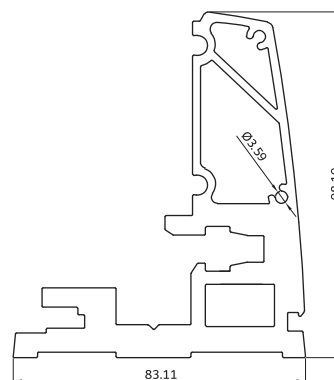
**HB-201**

5290 gr/m

پروفیل شیشه گیر
glass stuck

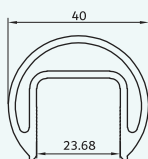
**HB-204**

846 gr/m

پروفیل شیشه گیر بالا
glass stuck up

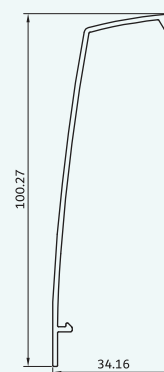
**HB-203**

550 gr/m

پروفیل درپوش
facing profiles

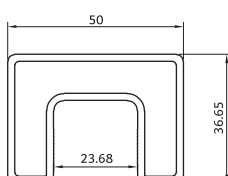
**HB-206**

1160 gr/m

پروفیل شیشه گیر بالا
glass stuck up

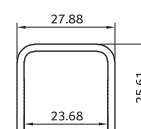
**HB-205**

420 gr/m

پروفیل شیشه گیر بالا
glass stuck up

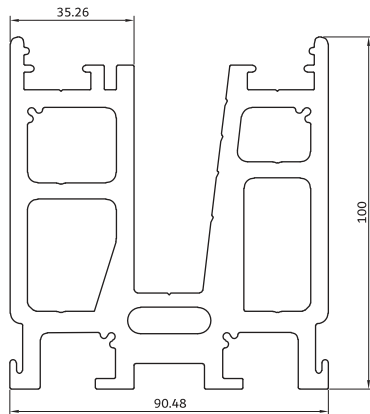

HB-220

9390 gr/m

پروفیل شیشه گیر
glass stuck

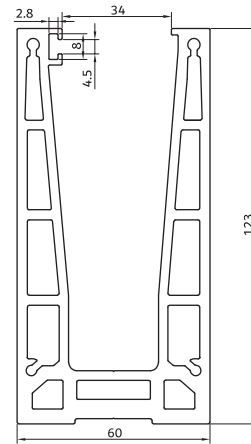

HB-207

2850 gr/m

پروفیل شیشه گیر
glass stuck

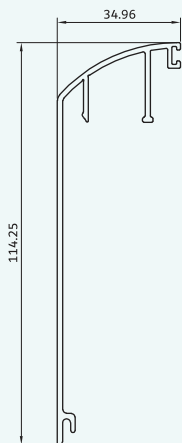

HB-221

9390 gr/m

پروفیل روکش
facing profiles

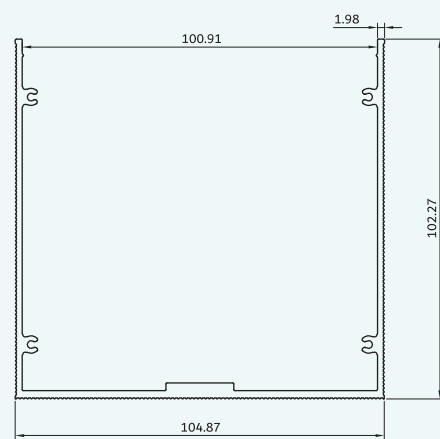

HB-222

1970 gr/m

پروفیل یو شکل داخل سطح
facing profiles

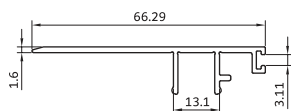

HB-223

430 gr/m

پروفیل کاور
cover profiles



HB-224

430 gr/m

پروفیل کالیبره
align profiles

سیستم های نرده شیشه ای

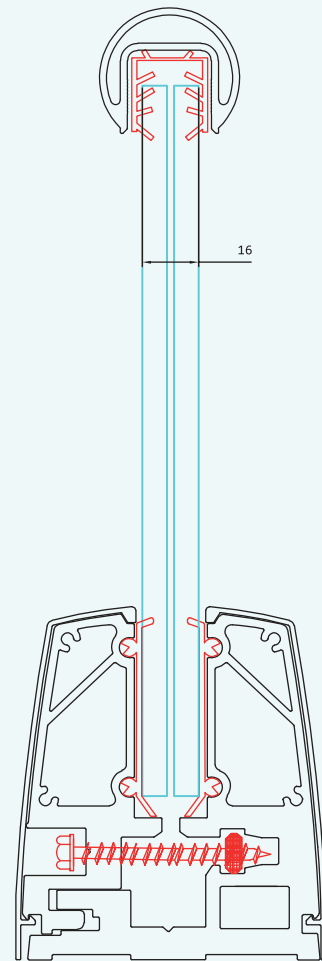
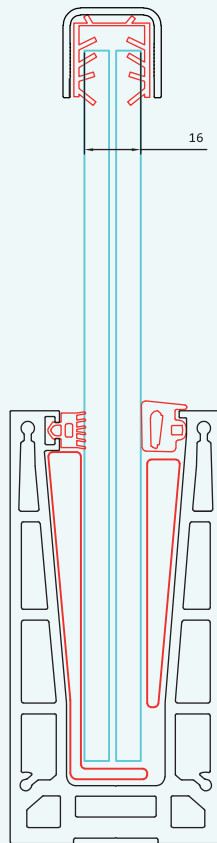
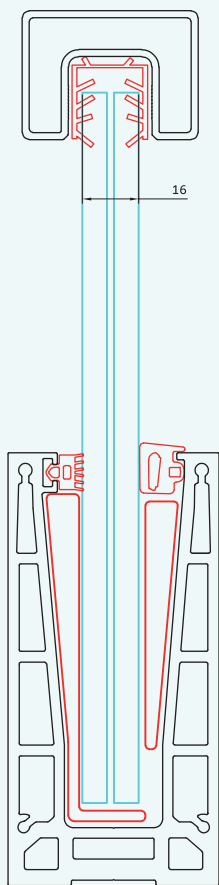



louvre
سیستم لوور



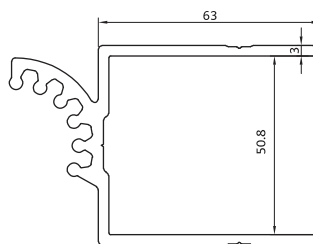

HB-P111

2036 gr/m

منقاری لوور

rotational louvre

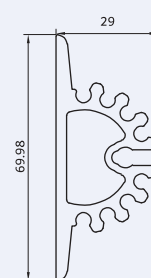

HB-P101

1464 gr/m

نگهدارنده لوور

basic louvre

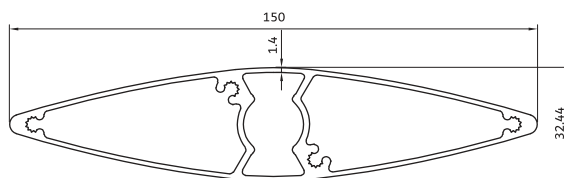

HB-L103

1800 gr/m

لوور ۱۵ دوکی

oval louvre

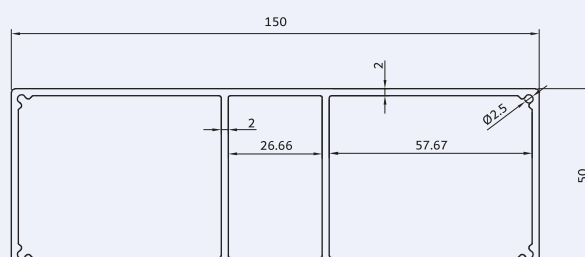

HB-L109

2635 gr/m

لوور ۱۵ مستطیل

rectangle louvre

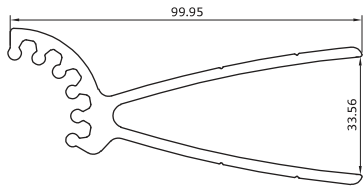

HB-M102

2033 gr/m

منقاری لوور
rotational louvre

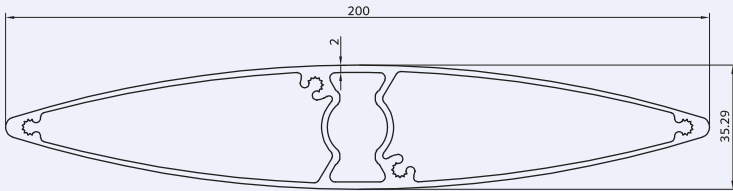

HB-L104

2400 gr/m

لوور ۲۰ دوکی
oval louvre

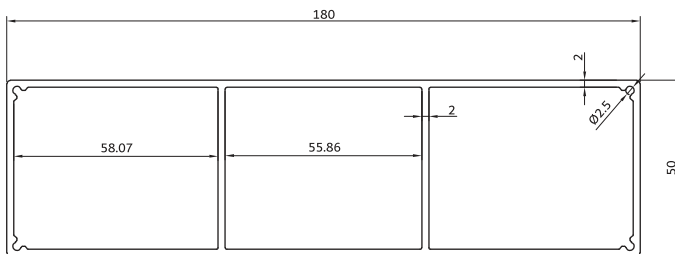

HB-L110

2980 gr/m

لوور ۱۸ مستطیل
rectangle louvre

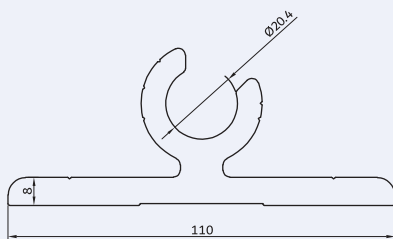

HB-P105

3672 gr/m

نگهدارنده لوور
basic louvre

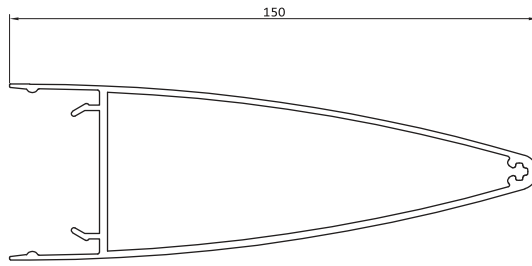

**HB-L107**

1900 gr/m

پروفیل ابتدا و انتهای لوور
profiles at the beginning end

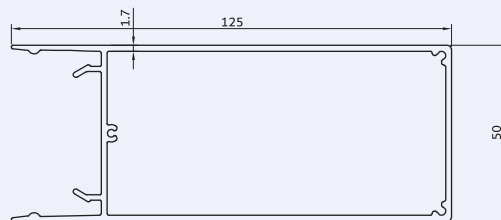
**HB-L112**

1665 gr/m

پروفیل ابتدا و انتهای لوور
profiles at the beginning end

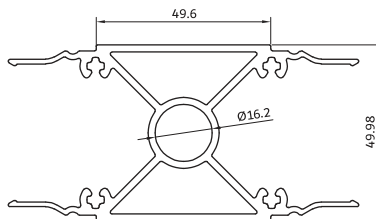
**HB-V108**

2060 gr/m

پروفیل میانی لوور
middle louvre

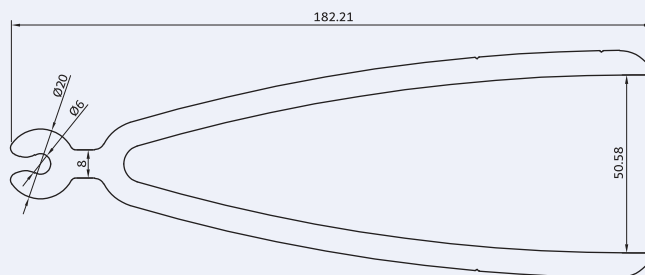
**HB-M106**

6812 gr/m

منقاری لوور
rotational louvre

سیستم لوور

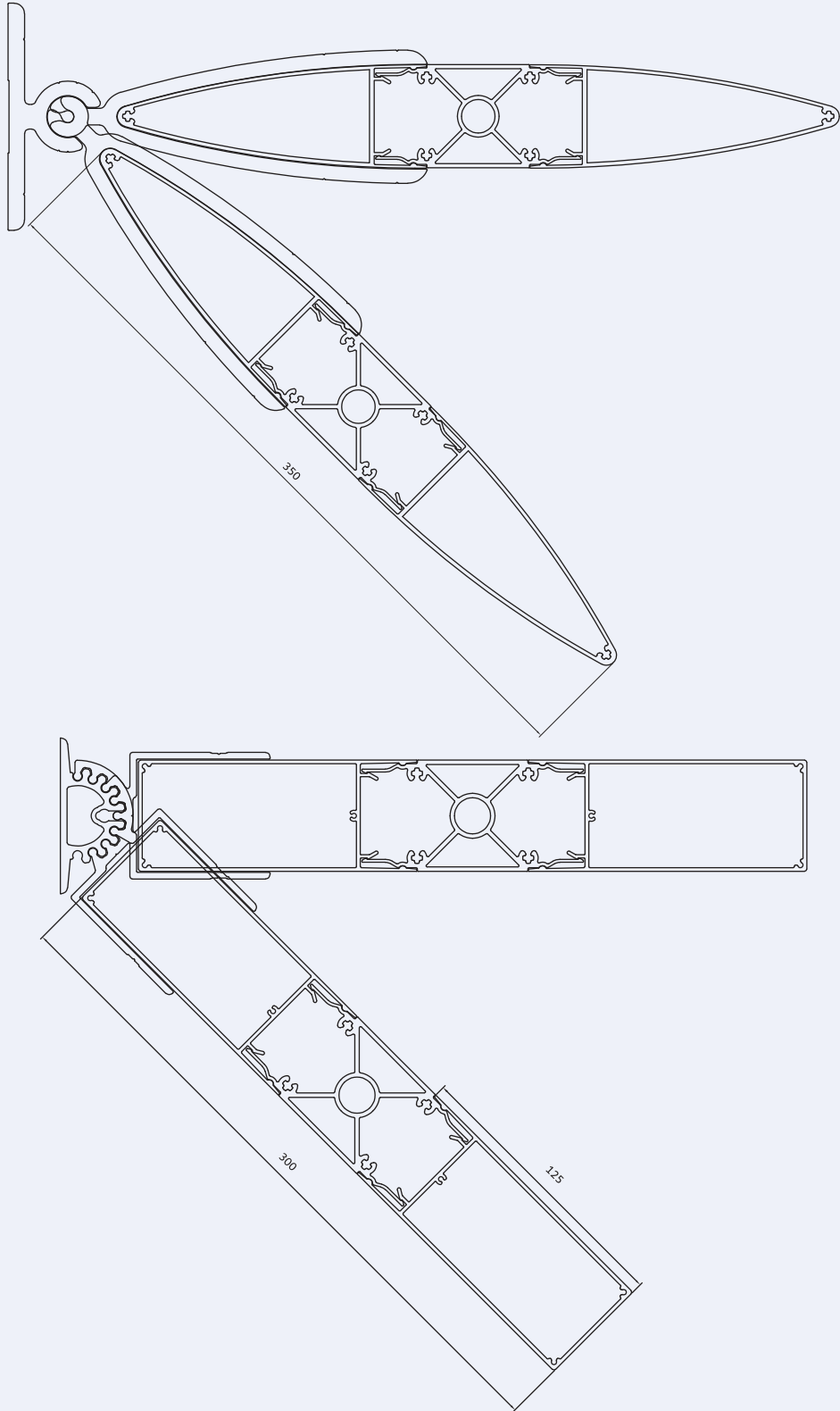

سیستم لوور

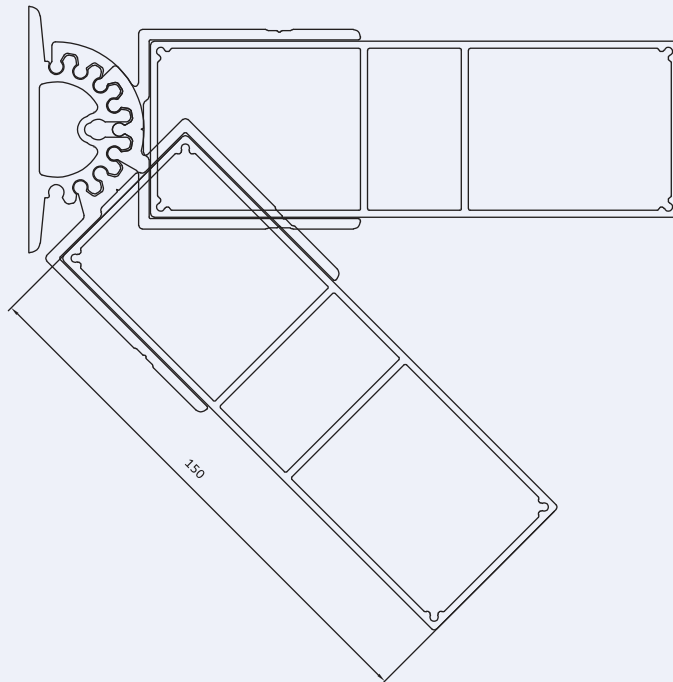
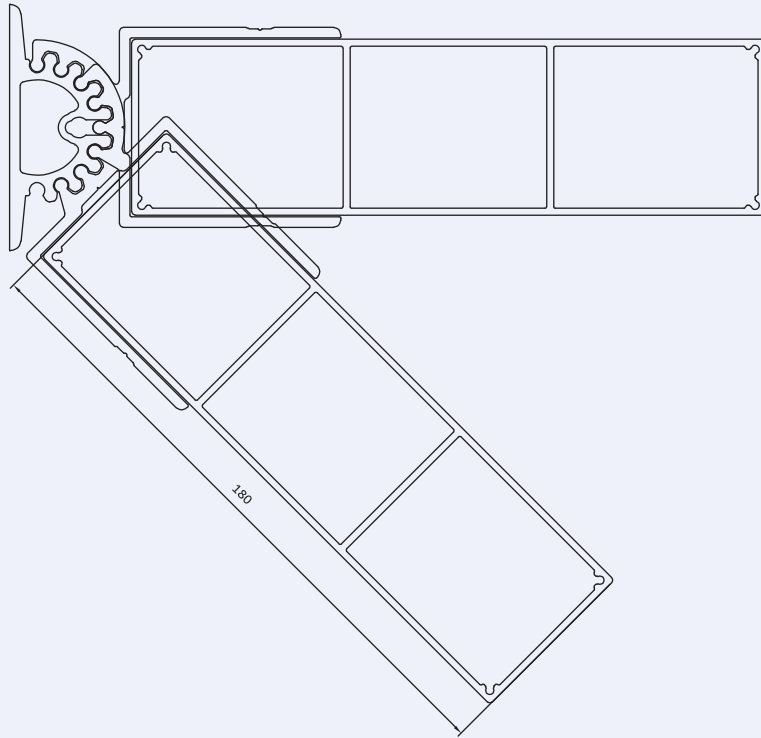

سیستم لوور

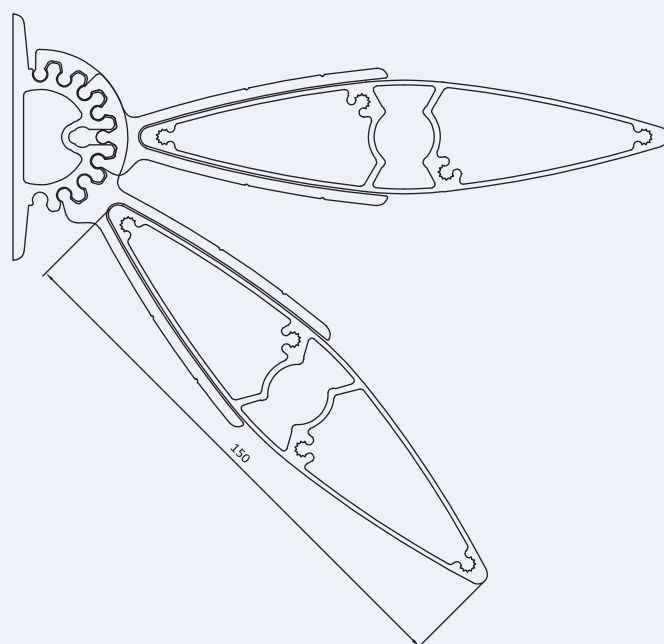
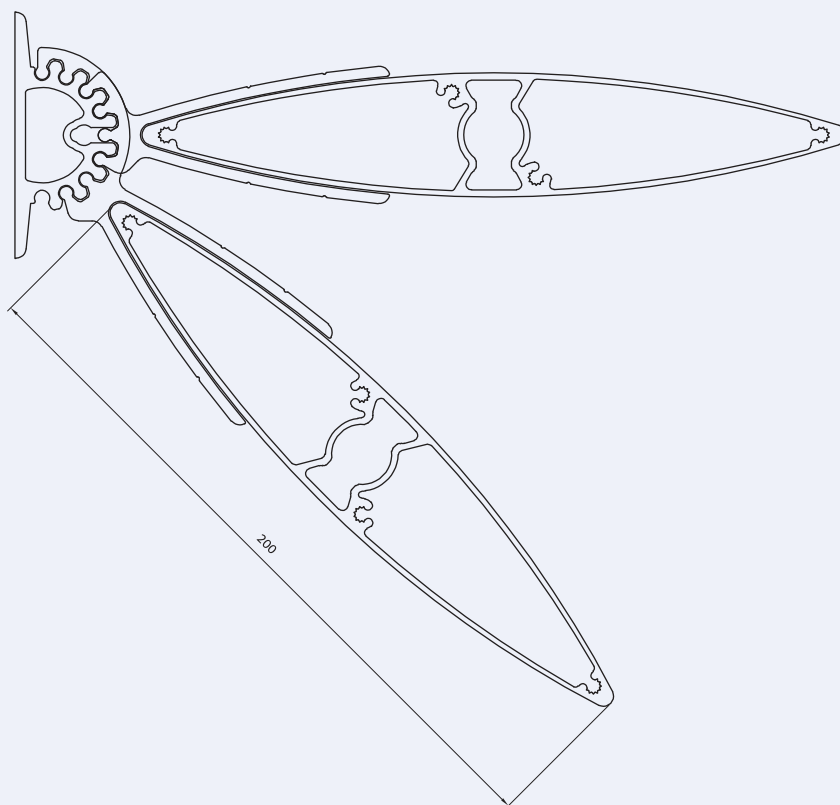



Habibi Industrial Group

تولید کننده بیلت DC، انواع پروفیل آلومینیومی
رنگ پودری و آنداپزینگ



Other profiles

سایر پروفیل ها



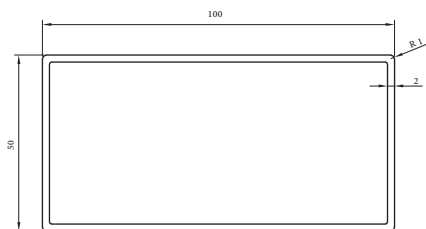

10 & 5
1580 gr/m

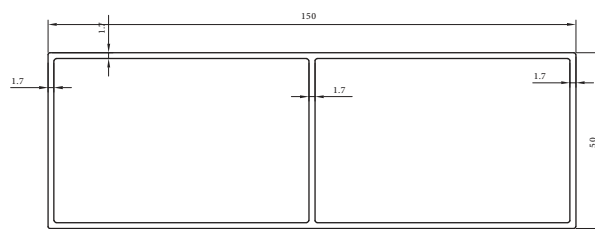

15 & 5
2025 gr/m

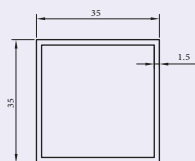

35 & 35
540 gr/m

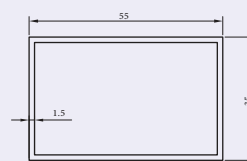

35 & 55
700 gr/m

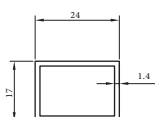

17 & 24
308 gr/m

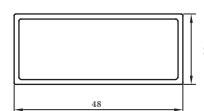

20 & 48
495 gr/m

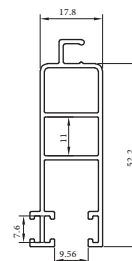

ka-549

605 gr/m

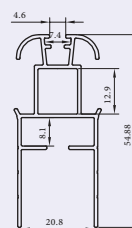

ka-537

500 gr/m

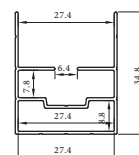

ka-538

320 gr/m

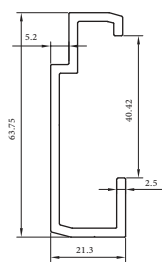

kilips-70
790 gr/m

klips profie

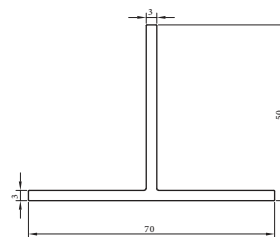

T-70
945 gr/m

vertical profie T

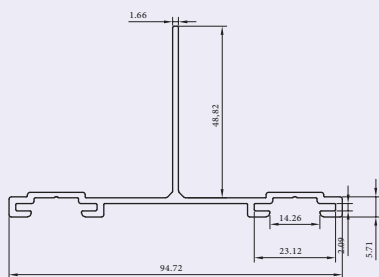

raner-2
840 gr/m

double vertical profie

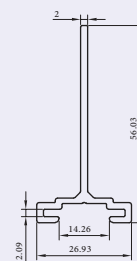

raner-1
489 gr/m

one vertical profie

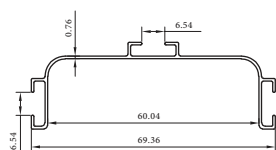

MA-101
284 gr/m

دستگیره یو مخفی
U hidden handle

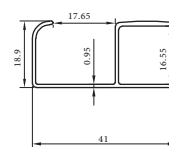

MA-100
257 gr/m

دستگیره هلالی
arched handle

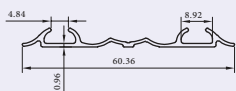

MA-103
219 gr/m

ریل طرح سارو
rail profile

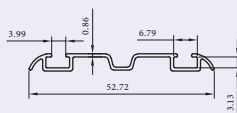

MA-104
192 gr/m

ریل خزینه دار
rail profile

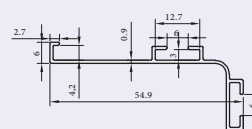

MA-102
252 gr/m

دستگیره ال مخفی
L hidden handle

Angel (ARP)



Light Champagne / C 32



Dark Champagne / C 325



Light Bronze / C 33



Dark Bronze / C 335



Brown / C 34



Black / C 35



Silver / C 0



Gold

Elegance (ASP)



Champagne Patina / C 325



Bronze Patina / C 335



Black Patina / C 35



Silver Patina / C 0

Antique (ASN)



Champagne Patina / C 325



Bronze Patina / C 335



Black Patina / C 35



Silver Patina / C 0

Venus (ARC)



Light Champagne / C 32



Dark Champagne / C 325



Light Bronze / C 33



Dark Bronze / C 335



Brown / C 34



Black / C 35



Silver / C 0



Gold

Prestige (ATS)



Light Champagne / C 32



Dark Champagne / C 325



Light Bronze / C 33



Dark Bronze / C 335



Brown / C 34



Black / C 35



Silver / C 0



Gold



Habibi Industrial Group

تولید کننده پیلت DC، انواع پروفیل آلومینیومی
رنگ پودری و آنداپزینگ

